

4

Distributed Forces, Centre of Gravity and Moment of Inertia

The term 'distributed force' has been explained in Art 2.11 and this applied force has been classified into linear surface and the body force. The number of such forces acting on a body is infinite. However, these forces can be replaced by their resultant which acts through a point, known as the centre of gravity of the body. In this chapter the method of finding areas of given figures and volumes is explained. Then the terms centroid and centre of gravity and second moment of area (moment of inertia of areas) are explained and method of finding them is illustrated with examples. Theorem of Pappus-Guldinus is introduced which is very useful for finding surface areas and volumes of solids then the method of finding centre of gravity and moment of inertia (mass moment of inertia) of solids is illustrated.

4.1 DETERMINATION OF AREAS AND VOLUMES

In the school education methods of finding areas and volumes of simple cases are taught by many methods. Here we will see the general approach which is common to all cases *i.e.* by the method of integration. In this method the expression for an elemental area will be written then suitable integrations are carried out so as to take care of entire surface/volume. This method is illustrated with standard cases below, first for finding the areas and latter for finding the volumes:

A: Area of Standard Figures

(i) Area of a rectangle

Let the size of rectangle be $b \times d$ as shown in Fig. 4.1. dA is an elemental area of side $dx \times dy$.

$$\begin{aligned} \text{Area of rectangle, } A &= \oint dA = \int_{-b/2}^{b/2} \int_{-d/2}^{d/2} dx dy \\ &= [x]_{-b/2}^{b/2} [y]_{-d/2}^{d/2} \\ &= bd. \end{aligned}$$

If we take element as shown in Fig. 4.2,

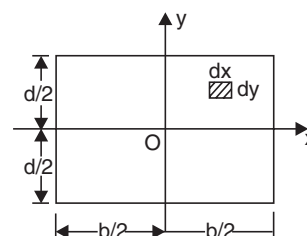

Fig. 4.1

$$\begin{aligned}
 A &= \int_{-d/2}^{d/2} dA = \int_{-d/2}^{d/2} b \cdot dy \\
 &= b [y]_{-d/2}^{d/2} \\
 &= bd
 \end{aligned}$$

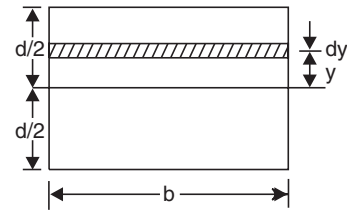

Fig. 4.2

(ii) Area of a triangle of base width 'b' height 'h': Referring to Fig. 4.3, let the element be selected as shown by hatched lines

Then $dA = b' dy = b \frac{y}{h} dy$

$$\begin{aligned}
 A &= \int_0^h dA = \int_0^h b \frac{y}{h} dy \\
 &= \frac{b}{h} \left[\frac{y^2}{2} \right]_0^h = \frac{bh}{2}
 \end{aligned}$$

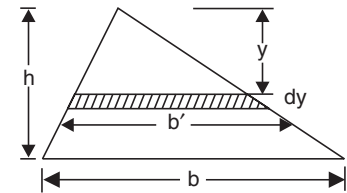

Fig. 4.3

(iii) Area of a circle

Consider the elemental area $dA = r d\theta dr$ as shown in Fig. 4.4. Now,

$$dA = r d\theta dr$$

r varies from 0 to R and θ varies from 0 to 2π

$$\begin{aligned}
 \therefore A &= \int_0^{2\pi} \int_0^R r d\theta dr \\
 &= \int_0^{2\pi} \left[\frac{r^2}{2} \right]_0^R d\theta \\
 &= \int_0^{2\pi} \frac{R^2}{2} d\theta \\
 &= \frac{R^2}{2} [\theta]_0^{2\pi} \\
 &= \frac{R^2}{2} \cdot 2\pi = \pi R^2
 \end{aligned}$$

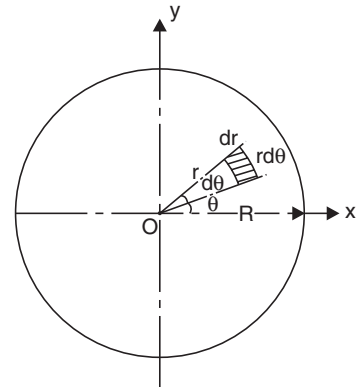

Fig. 4.4

In the above derivation, if we take variation of θ from 0 to π , we get the area of semicircle as $\frac{\pi R^2}{2}$ and if the limit is from 0 to $\pi/2$ the area of quarter of a circle is obtained as $\frac{\pi R^2}{4}$.

(iv) Area of a sector of a circle

Area of a sector of a circle with included angle 2α shown in Fig. 4.5 is to be determined. The elemental area is as shown in the figure

$$dA = r d\theta \cdot dr$$

θ varies from $-\alpha$ to α and r varies from 0 to R

$$\begin{aligned} \therefore A &= \oint dA = \int_{-\alpha}^{\alpha} \int_0^R r \, d\theta \, dr \\ &= \int_{-\alpha}^{\alpha} \left[\frac{r^2}{2} \right]_0^R d\theta = \int_{-\alpha}^{\alpha} \frac{R^2}{2} d\theta \\ &= \left[\frac{R^2}{2} \theta \right]_{-\alpha}^{\alpha} = \frac{R^2}{2} (2\alpha) = R^2 \alpha. \end{aligned}$$

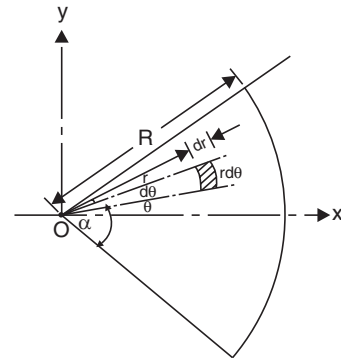

Fig. 4.5

(v) Area of a parabolic spandrel

Two types of parabolic curves are possible

(a) $y = kx^2$

(b) $y^2 = kx$

Case a: This curve is shown in Fig. 4.6.

The area of the element

$$\begin{aligned} dA &= y \, dx \\ &= kx^2 \, dx \end{aligned}$$

$$\begin{aligned} \therefore A &= \int_0^a dA = \int_0^a kx^2 \, dx \\ &= k \left[\frac{x^3}{3} \right]_0^a = \frac{ka^3}{3} \end{aligned}$$

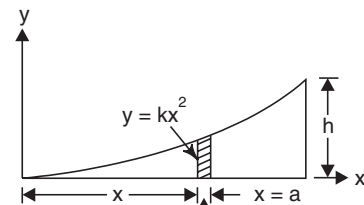

Fig. 4.6

We know, when $x = a$, $y = h$

$$\text{i.e., } h = ka^2 \text{ or } k = \frac{h}{a^2}$$

$$\therefore A = \frac{ka^3}{3} = \frac{h}{a^2} \frac{a^3}{3} = \frac{1}{3} ha = \frac{1}{3} \text{rd the area of rectangle of size } a \times h$$

Case b: In this case $y^2 = kx$

Referring to Fig. 4.7

$$dA = y \, dx = \sqrt{kx} \, dx$$

$$A = \int_0^a y \, dx = \int_0^a \sqrt{kx} \, dx$$

$$= \sqrt{k} \left[x^{3/2} \frac{2}{3} \right]_0^a = \sqrt{k} \frac{2}{3} a^{3/2}$$

We know that, when $x = a, y = h$

$$\therefore h^2 = ka \quad \text{or} \quad k = \frac{h^2}{a}$$

Hence $A = \frac{h}{\sqrt{a}} \cdot \frac{2}{3} \cdot a^{3/2}$

i.e., $A = \frac{2}{3} ha = \frac{2}{3} \text{rd the area of rectangle of size } a \times h.$

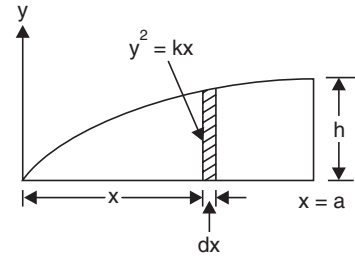

Fig. 4.7

(vi) Surface area of a cone

Consider the cone shown in Fig. 4.8. Now,

$$y = \frac{x}{h} R$$

Surface area of the element,

$$dA = 2\pi y dl = 2\pi \frac{x}{h} R dl$$

$$= 2\pi \frac{x}{h} R \frac{dx}{\sin \alpha}$$

$$\therefore A = \frac{2\pi R}{h \sin \alpha} \left[\frac{x^2}{2} \right]_0^h$$

$$= \frac{\pi R h}{\sin \alpha} = \pi R l$$

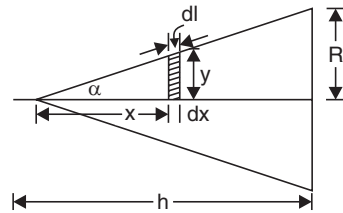

Fig. 4.8

(vii) Surface area of a sphere

Consider the sphere of radius R shown in Fig. 4.9. The element considered is the parallel circle at distance y from the diametral axis of sphere.

$$dS = 2\pi x R d\theta$$

$$= 2\pi R \cos \theta R d\theta, \text{ since } x = R \cos \theta$$

$$\therefore S = 2\pi R^2 \int_{-\pi/2}^{\pi/2} \cos \theta d\theta$$

$$= 2\pi R^2 [\sin \theta]_{-\pi/2}^{\pi/2}$$

$$= 4\pi R^2$$

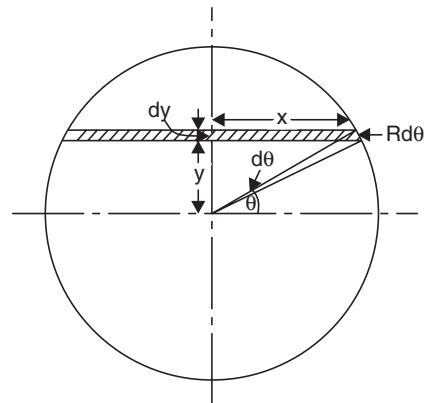

Fig. 4.9

B: Volume of Standard Solids

(i) Volume of a parallelepiped

Let the size of the parallelepiped be $a \times b \times c$. The volume of the element is

$$dV = dx \, dy \, dz$$

$$V = \int_0^a \int_0^b \int_0^c dx \, dy \, dz$$

$$= [x]_0^a [y]_0^b [z]_0^c = abc$$

(ii) Volume of a cone

Referring to Fig. 4.8

$$dV = \pi y^2 \cdot dx = \pi \frac{x^2}{h^2} R^2 dx, \quad \text{since } y = \frac{x}{h} R$$

$$V = \frac{\pi}{h^2} R^2 \int_0^h x^2 \, dx = \frac{\pi}{h^2} R^2 \left[\frac{x^3}{3} \right]_0^h$$

$$= \frac{\pi}{h^2} R^2 \frac{h^3}{3} = \frac{\pi R^2 h}{3}$$

(iii) Volume of a sphere

Referring to Fig. 4.9

$$dV = \pi x^2 \cdot dy$$

But $x^2 + y^2 = R^2$

i.e., $x^2 = R^2 - y^2$

$\therefore dV = \pi (R^2 - y^2) dy$

$$V = \int_{-R}^R \pi (R^2 - y^2) dy$$

$$= \pi \left[R^2 y - \frac{y^3}{3} \right]_{-R}^R$$

$$= \pi \left[R^2 \cdot R - \frac{R^3}{3} - \left\{ -R^3 - \frac{(-R)^3}{3} \right\} \right]$$

$$= \pi R^3 \left[1 - \frac{1}{3} + 1 - \frac{1}{3} \right] = \frac{4}{3} \pi R^3$$

The surface areas and volumes of solids of revolutions like cone, spheres may be easily found using theorems of Pappus and Guldinus. This will be taken up later in this chapter, since it needs the term centroid of generating lines.

4.2 CENTRE OF GRAVITY AND CENTROIDS

Consider the suspended body shown in Fig. 4.10(a). The self weight of various parts of this body are acting vertically downward. The only upward force is the force T in the string. To satisfy the equilibrium condition the resultant weight of the body, W must act along the line of string 1-1. Now, if the position is changed and the body is suspended again (Fig. 4.10(b)), it will reach equilibrium condition in a particular position. Let the line of action of the resultant weight be 2-2 intersecting 1-1 at G . It is obvious that if the body is suspended in any other position, the line of action of resultant weight W passes through G . This point is called the centre of gravity of the body. Thus *centre of gravity can be defined as the point through which the resultant of force of gravity of the body acts.*

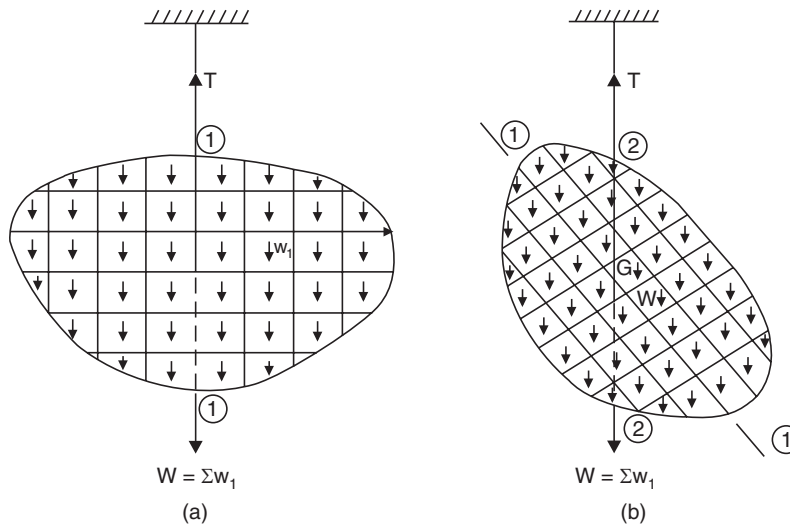

Fig. 4.10

The above method of locating centre of gravity is the practical method. If one desires to locating centre of gravity of a body analytically, it is to be noted that the resultant of weight of various portions of the body is to be determined. For this Varignon’s theorem, which states the moment of resultant force is equal to the sum of moments of component forces, can be used.

Referring to Fig. 4.11, let W_i be the weight of an element in the given body. W be the total weight of the body. Let the coordinates of the element be x_i, y_i, z_i and that of centroid G be x_c, y_c, z_c . Since W is the resultant of W_i forces,

$$W = W_1 + W_2 + W_3 + \dots = \Sigma W_i$$

and $Wx_c = W_1x_1 + W_2x_2 + W_3x_3 + \dots$

$\therefore Wx_c = \Sigma W_i x_i = \oint x dw$

Similarly, $Wy_c = \Sigma W_i y_i = \oint y dw$

and $Wz_c = \Sigma W_i z_i = \oint z dw$

...(4.1)

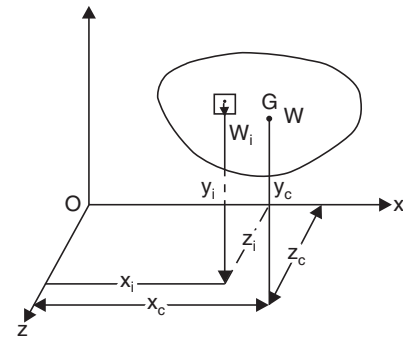

Fig. 4.11

If M is the mass of the body and m_i that of the element, then

$$M = \frac{W}{g} \quad \text{and} \quad m_i = \frac{W_i}{g}, \text{ hence we get}$$

$$\left. \begin{aligned} Mx_c &= \sum m_i x_i = \oint x_i dm \\ My_c &= \sum m_i y_i = \oint y_i dm \\ Mz_c &= \sum m_i z_i = \oint z_i dm \end{aligned} \right\} \dots(4.2)$$

and

If the body is made up of uniform material of unit weight γ then we know $W_i = V_i \gamma$, where V represents volume, then equation 4.1 reduces to

$$\left. \begin{aligned} Vx_c &= \sum V_i x_i = \oint x dV \\ Vy_c &= \sum V_i y_i = \oint y dV \\ Vz_c &= \sum V_i z_i = \oint z dV \end{aligned} \right\} \dots(4.3)$$

If the body is a flat plate of uniform thickness, in x - y plane, $W_i = \gamma A_i t$ (Ref. Fig. 4.12). Hence equation 4.1 reduces to

$$\left. \begin{aligned} Ax_c &= \sum A_i x_i = \oint x dA \\ Ay_c &= \sum A_i y_i = \oint y dA \end{aligned} \right\} \dots(4.4)$$

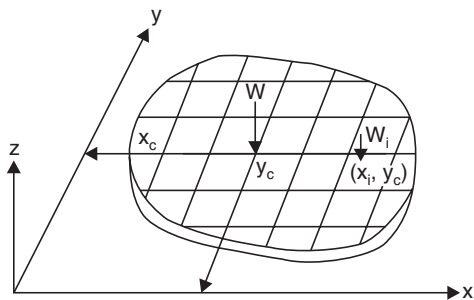

Fig. 4.12

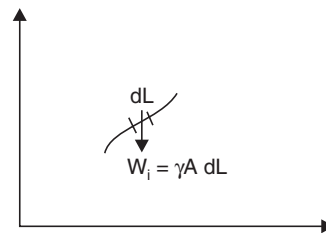

Fig. 4.13

If the body is a wire of uniform cross-section in plane x, y (Ref. Fig. 4.13) the equation 4.1 reduces to

$$\left. \begin{aligned} Lx_c &= \sum L_i x_i = \oint x dL \\ Ly_c &= \sum L_i y_i = \oint y dL \end{aligned} \right\} \dots(4.5)$$

The term centre of gravity is used only when the gravitational forces (weights) are considered. This term is applicable to solids. Equations 4.2 in which only masses are used the point obtained is termed as *centre of mass*. The central points obtained for volumes, surfaces and line segments (obtained by eqn. 4.3, 4.4 and 4.5) are termed as *centroids*.

4.3 CENTROID OF A LINE

Centroid of a line can be determined using equation 4.5. Method of finding the centroid of a line for some standard cases is illustrated below:

(i) *Centroid of a straight line*

Selecting the x -coordinate along the line (Fig. 4.14)

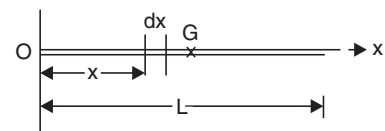

Fig. 4.14

$$Lx_c = \int_0^L x \, dx = \left[\frac{x^2}{2} \right]_0^L = \frac{L^2}{2}$$

$$\therefore x_c = \frac{L}{2}$$

Thus the centroid lies at midpoint of a straight line, whatever be the orientation of line (Ref. Fig. 4.15).

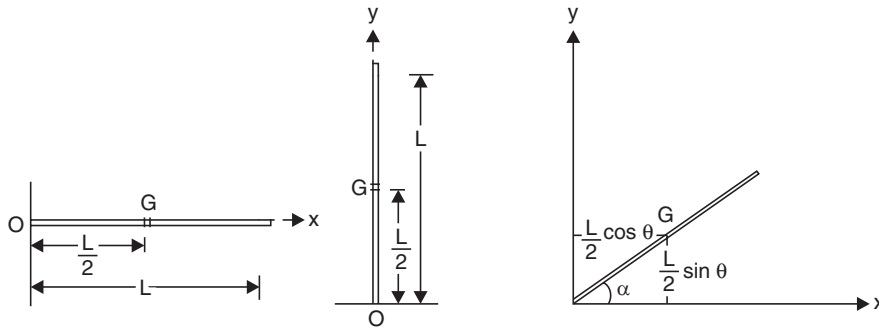

Fig. 4.15

(ii) Centroid of an arc of a circle

Referring to Fig. 4.16,

$$L = \text{Length of arc} = R 2\alpha$$

$$dL = R d\theta$$

Hence from eqn. 4.5

$$x_c L = \int_{-\alpha}^{\alpha} x dL$$

i.e.,
$$x_c R 2\alpha = \int_{-\alpha}^{\alpha} R \cos \theta \cdot R d\theta$$

$$= R^2 \left[\sin \theta \right]_{-\alpha}^{\alpha}$$

$$\therefore x_c = \frac{R^2 \times 2 \sin \alpha}{2R\alpha} = \frac{R \sin \alpha}{\alpha}$$

and
$$y_c L \int_{-\alpha}^{\alpha} y \, dL = \int_{-\alpha}^{\alpha} R \sin \theta \cdot R d\theta$$

$$= R^2 \left[\cos \theta \right]_{-\alpha}^{\alpha}$$

$$= 0$$

$$\therefore y_c = 0$$

From equation (i) and (ii) we can get the centroid of semicircle shown in Fig. 4.17 by putting $\alpha = \pi/2$ and for quarter of a circle shown in Fig. 4.18 by putting α varying from zero to $\pi/2$.

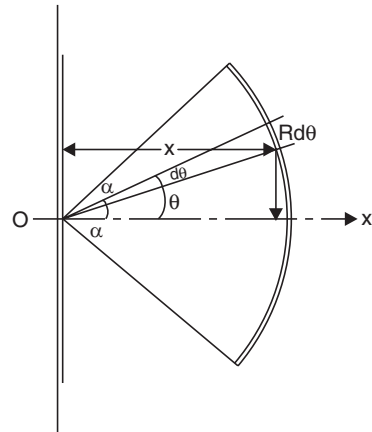

Fig. 4.16

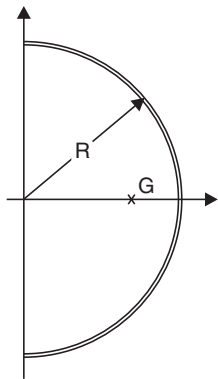

Fig. 4.17

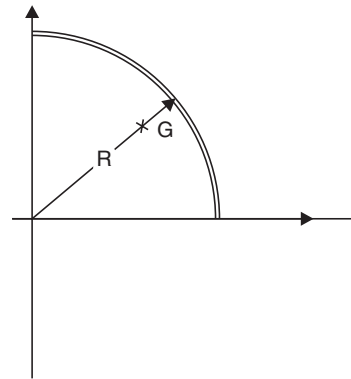

Fig. 4.18

For semicircle $x_c = \frac{2R}{\pi}$

$$y_c = 0$$

For quarter of a circle,

$$x_c = \frac{2R}{\pi}$$

$$y_c = \frac{2R}{\pi}$$

(iii) *Centroid of composite line segments*

The results obtained for standard cases may be used for various segments and then the equations 4.5 in the form

$$x_c L = \sum L_i x_i$$

$$y_c L = \sum L_i y_i$$

may be used to get centroid x_c and y_c . If the line segments is in space the expression $z_c L = \sum L_i z_i$ may also be used. The method is illustrated with few examples below:

Example 4.1. Determine the centroid of the wire shown in Fig. 4.19.

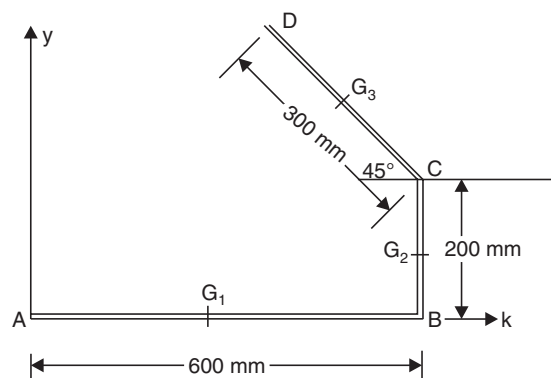

Fig. 4.19

Solution: The wire is divided into three segments AB , BC and CD . Taking A as origin the coordinates of the centroids of AB , BC and CD are

$$G_1(300, 0); G_2(600, 100) \text{ and } G_3(600 - 150 \cos 45^\circ, 200 + 150 \sin 45^\circ)$$

$$\text{i.e., } G_3(493.93, 306.07)$$

$$L_1 = 600 \text{ mm}, L_2 = 200 \text{ mm}, L_3 = 300 \text{ mm}$$

$$\therefore \text{ Total length } L = 600 + 200 + 300 = 1100 \text{ mm}$$

\therefore From the eqn. $Lx_c = \sum L_i x_i$, we get

$$\begin{aligned} 1100 x_c &= L_1 x_1 + L_2 x_2 + L_3 x_3 \\ &= 600 \times 300 + 200 \times 600 + 300 \times 493.93 \end{aligned}$$

$$\therefore x_c = 407.44 \text{ mm}$$

Now, $Ly_c = \sum L_i y_i$

$$1100 y_c = 600 \times 0 + 200 \times 100 + 300 \times 306.07$$

$$\therefore y_c = 101.66 \text{ mm}$$

Example 4.2. Locate the centroid of the uniform wire bent as shown in Fig. 4.20.

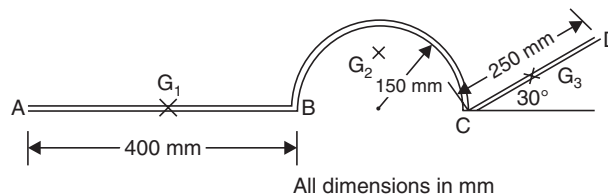

Fig. 4.20

Solution: The composite figure is divided into three simple figures and taking A as origin coordinates of their centroids noted down as shown below:

AB —a straight line

$$L_1 = 400 \text{ mm}, \quad G_1(200, 0)$$

BC —a semicircle

$$L_2 = 150 \pi = 471.24, \quad G_2 \left(475, \frac{2 \times 150}{\pi} \right)$$

$$\text{i.e. } G_2(475, 95.49)$$

CD —a straight line

$$L_3 = 250; x_3 = 400 + 300 + \frac{250}{2} \cos 30^\circ = 808.25 \text{ mm}$$

$$y_3 = 125 \sin 30^\circ = 62.5 \text{ mm}$$

$$\therefore \text{ Total length } L = L_1 + L_2 + L_3 = 1121.24 \text{ mm}$$

$\therefore Lx_c = \sum L_i x_i$ gives

$$1121.24 x_c = 400 \times 200 + 471.24 \times 475 + 250 \times 808.25$$

$$x_c = 451.20 \text{ mm}$$

$Ly_c = \sum L_i y_i$ gives

$$1121.24 y_c = 400 \times 0 + 471.24 \times 95.49 + 250 \times 62.5$$

$$y_c = 54.07 \text{ mm}$$

Example 4.3. Locate the centroid of uniform wire shown in Fig. 4.21. Note: portion AB is in x-z plane, BC in y-z plane and CD in x-y plane. AB and BC are semi circular in shape.

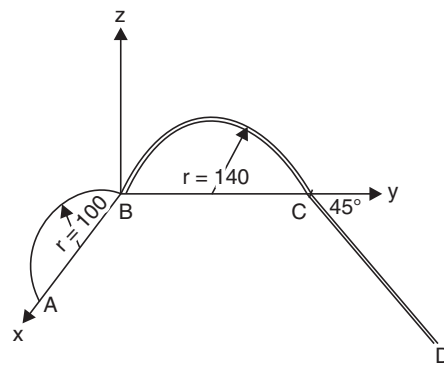

Fig. 4.21

Solution: The length and the centroid of portions AB, BC and CD are as shown in table below:

Table 4.1

Portion	L_i	x_i	y_i	z_i
AB	100π	100	0	$\frac{2 \times 100}{\pi}$
BC	140π	0	140	$\frac{2 \times 140}{\pi}$
CD	300	$300 \sin 45^\circ$	$280 + 300 \cos 45^\circ$ $= 492.13$	0

$$\therefore L = 100\pi + 140\pi + 300 = 1053.98 \text{ mm}$$

From eqn. $Lx_c = \sum L_i x_i$, we get

$$1053.98 x_c = 100\pi \times 100 + 140\pi \times 0 + 300 \times 300 \sin 45^\circ$$

$$x_c = 90.19 \text{ mm}$$

Similarly, $1053.98 y_c = 100\pi \times 0 + 140\pi \times 140 + 300 \times 492.13$

$$y_c = 198.50 \text{ mm}$$

$$\text{and } 1053.98 z_c = 100\pi \times \frac{200}{\pi} + 140\pi \times \frac{2 \times 140}{\pi} + 300 \times 0$$

$$z_c = 56.17 \text{ mm}$$

4.4 FIRST MOMENT OF AREA AND CENTROID

From equation 4.1, we have

$$x_c = \frac{\sum W_i x_i}{W}, \quad y_c = \frac{\sum W_i y_i}{W} \quad \text{and} \quad z_c = \frac{\sum W_i z_i}{W}$$

From the above equation we can make the statement that distance of centre of gravity of a body from an axis is obtained by dividing moment of the gravitational forces acting on the body, about the axis, by the total weight of the body. Similarly from equation 4.4, we have,

$$x_c = \frac{\Sigma A_i x_i}{A}, \quad y_c = \frac{\Sigma A_i y_i}{A}$$

By terming $\Sigma A_i x_i$ as the moment of area about the axis, we can say centroid of plane area from any axis is equal to moment of area about the axis divided by the total area. The moment of area $\Sigma A_i x_i$ is termed as first moment of area also just to differentiate this from the term $\Sigma A_i x_i^2$, which will be dealt latter. It may be noted that since the moment of area about an axis divided by total area gives the distance of the centroid from that axis, the moment of area is zero about any centroidal axis.

Difference between Centre of Gravity and Centroid

From the above discussion we can draw the following differences between centre of gravity and centroid:

- (1) The term centre of gravity applies to bodies with weight, and centroid applies to lines, plane areas and volumes.
- (2) Centre of gravity of a body is a point through which the resultant gravitational force (weight) acts for any orientation of the body whereas centroid is a point in a line plane area volume such that the moment of area about any axis through that point is zero.

Use of Axis of Symmetry

Centroid of an area lies on the axis of symmetry if it exists. This is useful theorem to locate the centroid of an area.

This theorem can be proved as follows:

Consider the area shown in Fig. 4.22. In this figure y-y is the axis of symmetry. From eqn. 4.4, the distance of centroid from this axis is given by:

$$\frac{\Sigma A_i x_i}{A}$$

Consider the two elemental areas shown in Fig. 4.22, which are equal in size and are equidistant from the axis, but on either side. Now the sum of moments of these areas cancel each other since the areas and distances are the same, but signs of distances are opposite. Similarly, we can go on considering an area on one side of symmetric axis and corresponding image area on the other side, and prove that total moments of area ($\Sigma A_i x_i$) about the symmetric axis is zero. Hence the distance of centroid from the symmetric axis is zero, *i.e.*, centroid always lies on symmetric axis.

Making use of the symmetry we can conclude that:

- (1) Centroid of a circle is its centre (Fig. 4.23);
- (2) Centroid of a rectangle of sides b and d is at distance $\frac{b}{2}$ and $\frac{d}{2}$ from the corner as shown in Fig. 4.24.

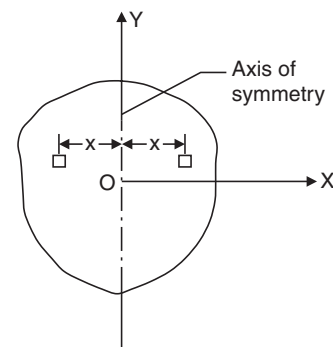

Fig. 4.22

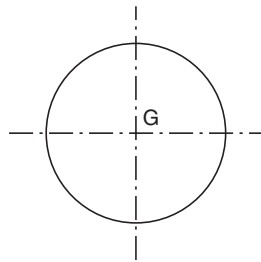

Fig. 4.23

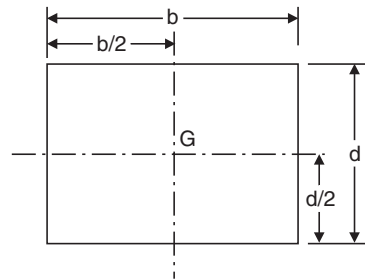

Fig. 4.24

Determination of Centroid of Simple Figures From First Principle

For simple figures like triangle and semicircle, we can write general expression for the elemental area and its distance from an axis. Then equation 4.4 reduces to:

$$\bar{y} = \frac{\int y dA}{A}$$

$$\bar{x} = \frac{\int x dA}{A}$$

The location of the centroid using the above equations may be considered as finding centroid from first principle. Now, let us find centroid of some standard figures from first principle.

Centroid of a Triangle

Consider the triangle ABC of base width b and height h as shown in Fig. 4.25. Let us locate the distance of centroid from the base. Let b_1 be the width of elemental strip of thickness dy at a distance y from the base. Since $\triangle AEF$ and $\triangle ABC$ are similar triangles, we can write:

$$\frac{b_1}{b} = \frac{h-y}{h}$$

$$b_1 = \left(\frac{h-y}{h}\right)b = \left(1 - \frac{y}{h}\right)b$$

\therefore Area of the element

$$= dA = b_1 dy$$

$$= \left(1 - \frac{y}{h}\right)b dy$$

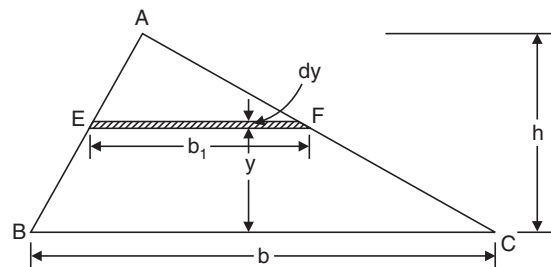

Fig. 4.25

Area of the triangle $A = \frac{1}{2}bh$

\therefore From eqn. 4.4

$$\bar{y} = \frac{\text{Moment of area}}{\text{Total area}} = \frac{\int y dA}{A}$$

Now,

$$\int y dA = \int_0^h y \left(1 - \frac{y}{h}\right)b dy$$

$$\begin{aligned}
 &= \int_0^h \left(y - \frac{y^2}{h} \right) b \, dy \\
 &= b \left[\frac{y^2}{2} - \frac{y^3}{3h} \right]_0^h \\
 &= \frac{bh^2}{6} \\
 \therefore \bar{y} &= \frac{\int y dA}{A} = \frac{bh^2}{6} \times \frac{1}{\frac{1}{2}bh} \\
 \therefore \bar{y} &= \frac{h}{3}
 \end{aligned}$$

Thus the centroid of a triangle is at a distance $\frac{h}{3}$ from the base (or $\frac{2h}{3}$ from the apex) of the triangle, where h is the height of the triangle.

Centroid of a Semicircle

Consider the semicircle of radius R as shown in Fig. 4.26. Due to symmetry centroid must lie on y axis. Let its distance from diametral axis be \bar{y} . To find \bar{y} , consider an element at a distance r from the centre O of the semicircle, radial width being dr and bound by radii at θ and $\theta + d\theta$.

Area of element = $r \, d\theta \, dr$.

Its moment about diametral axis x is given by:

$$r \, d\theta \times dr \times r \sin \theta = r^2 \sin \theta \, dr \, d\theta$$

\therefore Total moment of area about diametral axis,

$$\begin{aligned}
 \int_0^\pi \int_0^R r^2 \sin \theta \, dr \, d\theta &= \int_0^\pi \left[\frac{r^3}{3} \right]_0^R \sin \theta \, d\theta \\
 &= \frac{R^3}{3} \left[-\cos \theta \right]_0^\pi \\
 &= \frac{R^3}{3} [1 + 1] = \frac{2R^3}{3}
 \end{aligned}$$

Area of semicircle $A = \frac{1}{2} \pi R^2$

$$\begin{aligned}
 \therefore \bar{y} &= \frac{\text{Moment of area}}{\text{Total area}} = \frac{\frac{2R^3}{3}}{\frac{1}{2} \pi R^2} \\
 &= \frac{4R}{3\pi}
 \end{aligned}$$

Thus, the centroid of the circle is at a distance $\frac{4R}{3\pi}$ from the diametral axis.

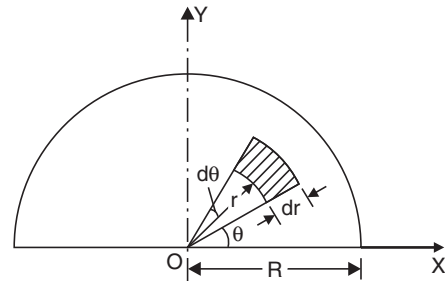

Fig. 4.26

Centroid of Sector of a Circle

Consider the sector of a circle of angle 2α as shown in Fig. 4.27. Due to symmetry, centroid lies on x axis. To find its distance from the centre O , consider the elemental area shown.

Area of the element $= r d\theta \times dr$

Its moment about y axis

$$= r d\theta \times dr \times r \cos \theta$$

$$= r^2 \cos \theta \, dr d\theta$$

\therefore Total moment of area about y axis

$$= \int_{-\alpha}^{\alpha} \int_0^R r^2 \cos \theta \, dr d\theta$$

$$= \left[\frac{r^3}{3} \right]_0^R \left[\sin \theta \right]_{-\alpha}^{\alpha}$$

$$= \frac{R^3}{3} 2 \sin \alpha$$

Total area of the sector

$$= \int_{-\alpha}^{\alpha} \int_0^R r \, dr d\theta$$

$$= \int_{-\alpha}^{\alpha} \left[\frac{r^2}{2} \right]_0^R d\theta$$

$$= \frac{R^2}{2} \left[\theta \right]_{-\alpha}^{\alpha}$$

$$= R^2 \alpha$$

\therefore The distance of centroid from centre O

$$= \frac{\text{Moment of area about } y \text{ axis}}{\text{Area of the figure}}$$

$$= \frac{\frac{2R^3}{3} \sin \alpha}{R^2 \alpha} = \frac{2R}{3\alpha} \sin \alpha$$

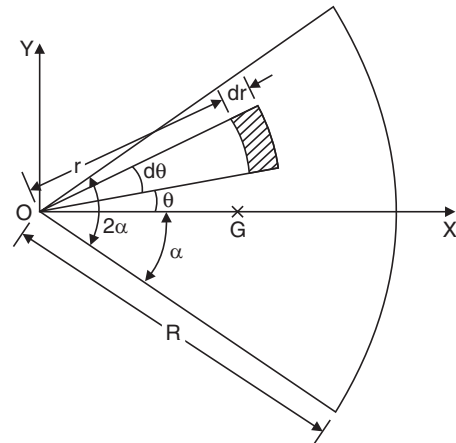

Fig. 4.27

Centroid of Parabolic Spandrel

Consider the parabolic spandrel shown in Fig. 4.28. Height of the element at a distance x from O is $y = kx^2$

Width of element = dx
 \therefore Area of the element = $kx^2 dx$

\therefore Total area of spandrel = $\int_0^a kx^2 dx = \left[\frac{kx^3}{3} \right]_0^a$
 $= \frac{ka^3}{3}$

Moment of area about y axis

$$= \int_0^a kx^2 dx \times x$$

$$= \int_0^a kx^3 dx$$

$$= \left[\frac{kx^4}{4} \right]_0^a$$

$$= \frac{ka^4}{4}$$

Moment of area about x axis = $\int_0^a dA \cdot \frac{y}{2}$

$$= \int_0^a kx^2 dx \cdot \frac{kx^2}{2} = \int_0^a \frac{k^2 x^4}{2} dx$$

$$= \frac{k^2 a^5}{10}$$

$\therefore \bar{x} = \frac{ka^4}{4} \div \frac{ka^3}{3} = \frac{3a}{4}$

$$\bar{y} = \frac{k^2 a^5}{10} \div \frac{ka^3}{3} = \frac{3}{10} ka^2$$

From the Fig. 4.28, at $x = a, y = h$

$\therefore h = ka^2$ or $k = \frac{h}{a^2}$

$\therefore \bar{y} = \frac{3}{10} \times \frac{h}{a^2} a^2 = \frac{3h}{10}$

Thus, centroid of spandrel is $\left(\frac{3a}{4}, \frac{3h}{10} \right)$

Centroids of some common figures are shown in Table 4.2.

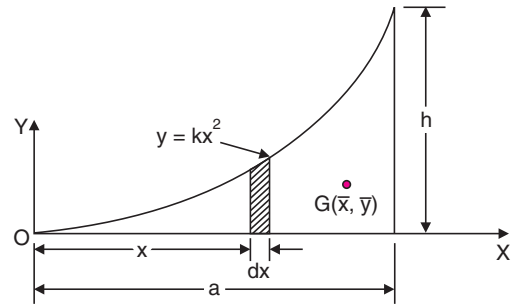
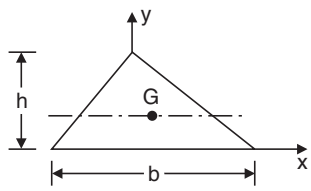
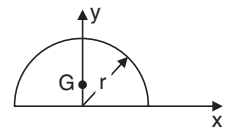
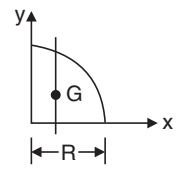
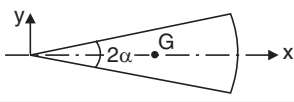
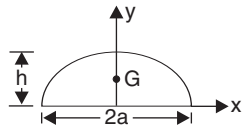
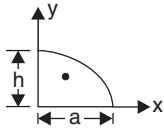
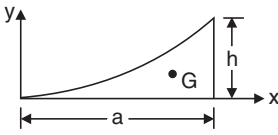

Fig. 4.28

Table 4.2 Centroid of Some Common Figures

Shape	Figure	\bar{x}	\bar{y}	Area
Triangle		—	$\frac{h}{3}$	$\frac{bh}{2}$
Semicircle		0	$\frac{4R}{3\pi}$	$\frac{\pi R^2}{2}$
Quarter circle		$\frac{4R}{3\pi}$	$\frac{4R}{3\pi}$	$\frac{\pi R^2}{4}$
Sector of a circle		$\frac{2R}{3\alpha} \sin \alpha$	0	αR^2
Parabola		0	$\frac{3h}{5}$	$\frac{4ah}{3}$
Semi parabola		$\frac{3}{8} a$	$\frac{3h}{5}$	$\frac{2ah}{3}$
Parabolic spandrel		$\frac{3a}{4}$	$\frac{3h}{10}$	$\frac{ah}{3}$

Centroid of Composite Sections

So far, the discussion was confined to locating the centroid of simple figures like rectangle, triangle, circle, semicircle, etc. In engineering practice, use of sections which are built up of many simple sections is very common. Such sections may be called as built-up sections or composite sections. To locate the centroid of composite sections, one need not go for the first principle (method of integration). The given composite section can be split into suitable simple figures and then the centroid of each simple figure can be found by inspection or using the standard formulae listed in Table 4.2. Assuming the area of the simple figure as concentrated at its centroid, its moment about an axis can be

found by multiplying the area with distance of its centroid from the reference axis. After determining moment of each area about reference axis, the distance of centroid from the axis is obtained by dividing total moment of area by total area of the composite section.

Example 4.4. Locate the centroid of the T-section shown in the Fig. 4.29.

Solution: Selecting the axis as shown in Fig. 4.29, we can say due to symmetry centroid lies on y axis, i.e. $\bar{x} = 0$. Now the given T-section may be divided into two rectangles A_1 and A_2 each of size 100×20 and 20×100 . The centroid of A_1 and A_2 are $g_1(0, 10)$ and $g_2(0, 70)$ respectively.

\therefore The distance of centroid from top is given by:

$$\bar{y} = \frac{100 \times 20 \times 10 + 20 \times 100 \times 70}{100 \times 20 + 20 \times 100}$$

$$= 40 \text{ mm}$$

Hence, **centroid of T-section is on the symmetric axis at a distance 40 mm from the top.**

Example 4.5. Find the centroid of the unequal angle $200 \times 150 \times 12$ mm, shown in Fig. 4.30.

Solution: The given composite figure can be divided into two rectangles:

$$A_1 = 150 \times 12 = 1800 \text{ mm}^2$$

$$A_2 = (200 - 12) \times 12 = 2256 \text{ mm}^2$$

Total area $A = A_1 + A_2 = 4056 \text{ mm}^2$

Selecting the reference axis x and y as shown in Fig. 4.30. The centroid of A_1 is $g_1(75, 6)$ and that of A_2 is:

$$g_2 \left[6, 12 + \frac{1}{2} (200 - 12) \right]$$

i.e., $g_2(6, 106)$

$$\bar{x} = \frac{\text{Moment about y axis}}{\text{Total area}}$$

$$= \frac{A_1 x_1 + A_2 x_2}{A}$$

$$= \frac{1800 \times 75 + 2256 \times 6}{4056} = 36.62 \text{ mm}$$

$$\bar{y} = \frac{\text{Moment about x axis}}{\text{Total area}}$$

$$= \frac{A_1 y_1 + A_2 y_2}{A}$$

$$= \frac{1800 \times 6 + 2256 \times 106}{4056} = 61.62 \text{ mm}$$

Thus, the centroid is at $\bar{x} = 36.62$ mm and $\bar{y} = 61.62$ mm as shown in the figure.

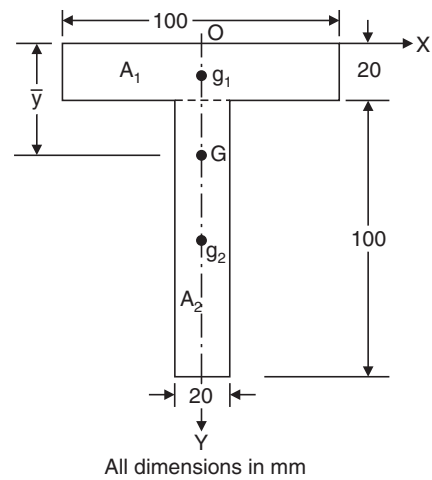

Fig. 4.29

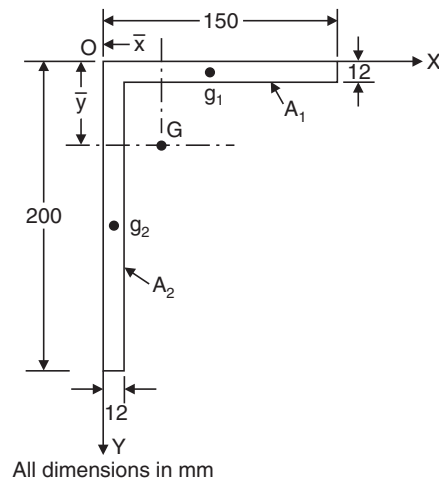

Fig. 4.30

Example 4.6. Locate the centroid of the I-section shown in Fig. 4.31.

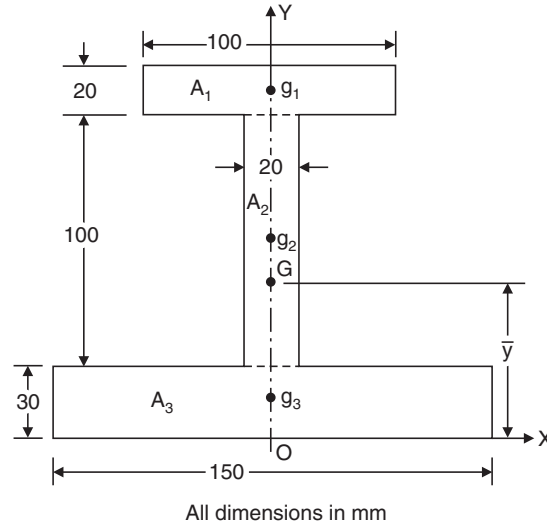

Fig. 4.31

Solution: Selecting the coordinate system as shown in Fig. 4.31, due to symmetry centroid must lie on y axis,

i.e., $\bar{x} = 0$

Now, the composite section may be split into three rectangles

$$A_1 = 100 \times 20 = 2000 \text{ mm}^2$$

Centroid of A_1 from the origin is:

$$y_1 = 30 + 100 + \frac{20}{2} = 140 \text{ mm}$$

Similarly

$$A_2 = 100 \times 20 = 2000 \text{ mm}^2$$

$$y_2 = 30 + \frac{100}{2} = 80 \text{ mm}$$

$$A_3 = 150 \times 30 = 4500 \text{ mm}^2,$$

and

$$y_3 = \frac{30}{2} = 15 \text{ mm}$$

$$\therefore \bar{y} = \frac{A_1 y_1 + A_2 y_2 + A_3 y_3}{A}$$

$$= \frac{2000 \times 140 + 2000 \times 80 + 4500 \times 15}{2000 + 2000 + 4500}$$

$$= 59.71 \text{ mm}$$

Thus, the centroid is on the symmetric axis at a distance 59.71 mm from the bottom as shown in Fig. 4.31.

Example 4.7. Determine the centroid of the section of the concrete dam shown in Fig. 4.32.

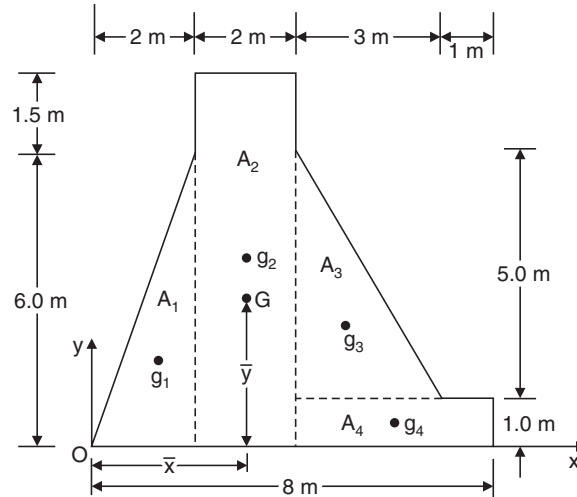

Fig. 4.32

Solution: Let the axis be selected as shown in Fig. 4.32. Note that it is convenient to take axis in such a way that the centroids of all simple figures are having positive coordinates. If coordinate of any simple figure comes out to be negative, one should be careful in assigning the sign of moment of area of that figure.

The composite figure can be conveniently divided into two triangles and two rectangles, as shown in Fig. 4.32.

Now,

$$A_1 = \frac{1}{2} \times 2 \times 6 = 6 \text{ m}^2$$

$$A_2 = 2 \times 7.5 = 15 \text{ m}^2$$

$$A_3 = \frac{1}{2} \times 3 \times 5 = 7.5 \text{ m}^2$$

$$A_4 = 1 \times 4 = 4 \text{ m}^2$$

$$A = \text{total area} = 32.5 \text{ m}^2$$

Centroids of simple figures are:

$$x_1 = \frac{2}{3} \times 2 = \frac{4}{3} \text{ m}$$

$$y_1 = \frac{1}{3} \times 6 = 2 \text{ m}$$

$$x_2 = 2 + 1 = 3 \text{ m}$$

$$y_2 = \frac{7.5}{2} = 3.75 \text{ m}$$

$$x_3 = 2 + 2 + \frac{1}{3} \times 3 = 5 \text{ m}$$

$$y_3 = 1 + \frac{1}{3} \times 5 = \frac{8}{3} \text{ m}$$

$$x_4 = 4 + \frac{4}{2} = 6 \text{ m}$$

$$y_4 = 0.5 \text{ m}$$

$$\bar{x} = \frac{A_1x_1 + A_2x_2 + A_3x_3 + A_4x_4}{A}$$

$$= \frac{6 \times \frac{4}{3} + 15 \times 3 + 7.5 \times 5 + 4 \times 6}{32.5}$$

$$= 3.523 \text{ m}$$

$$\bar{y} = \frac{A_1y_1 + A_2y_2 + A_3y_3 + A_4y_4}{A}$$

$$= \frac{6 \times 2 + 15 \times 3.75 + 7.5 \times \frac{8}{3} + 4 \times 0.5}{32.5}$$

$$= 2.777 \text{ m}$$

The centroid is at $\bar{x} = 3.523 \text{ m}$
and $\bar{y} = 2.777 \text{ m}$

Example 4.8. Determine the centroid of the area shown in Fig. 4.33 with respect to the axis shown.

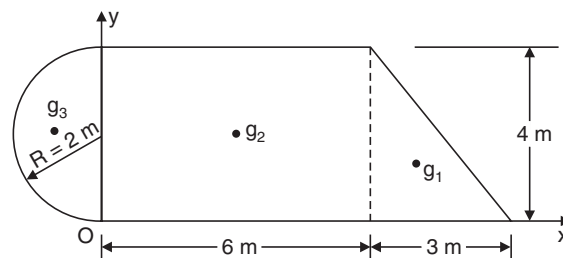

Fig. 4.33

Solution: The composite section is divided into three simple figures, a triangle, a rectangle and a semicircle

Now, area of triangle $A_1 = \frac{1}{2} \times 3 \times 4 = 6 \text{ m}^2$

Area of rectangle $A_2 = 6 \times 4 = 24 \text{ m}^2$

Area of semicircle $A_3 = \frac{1}{2} \times \pi \times 2^2 = 6.2832 \text{ m}^2$

\therefore Total area $A = 36.2832 \text{ m}^2$

The coordinates of centroids of these three simple figures are:

$$x_1 = 6 + \frac{1}{3} \times 3 = 7 \text{ m}$$

$$y_1 = \frac{4}{3} \text{ m}$$

$$x_2 = 3 \text{ m}$$

$$y_2 = 2 \text{ m}$$

$$x_3 = \frac{-4R}{3\pi} = -\frac{4 \times 2}{3\pi} = -0.8488 \text{ m}$$

$$y_3 = 2 \text{ m} \quad (\text{Note carefully the sign of } x_3).$$

$$\begin{aligned} \bar{x} &= \frac{A_1x_1 + A_2x_2 + A_3x_3}{A} \\ &= \frac{6 \times 7 + 24 \times 3 + 6.2832 \times (-0.8488)}{36.2832} \end{aligned}$$

i.e.,

$$\bar{x} = 2.995 \text{ m}$$

$$\begin{aligned} \bar{y} &= \frac{A_1y_1 + A_2y_2 + A_3y_3}{A} \\ &= \frac{\frac{6 \times 4}{3} + 24 \times 2 + 6.2832 \times 2}{36.2832} \end{aligned}$$

i.e.,

$$\bar{y} = 1.890 \text{ m}$$

Example 4.9. In a gusset plate, there are six rivet holes of 21.5 mm diameter as shown in Fig. 4.34. Find the position of the centroid of the gusset plate.

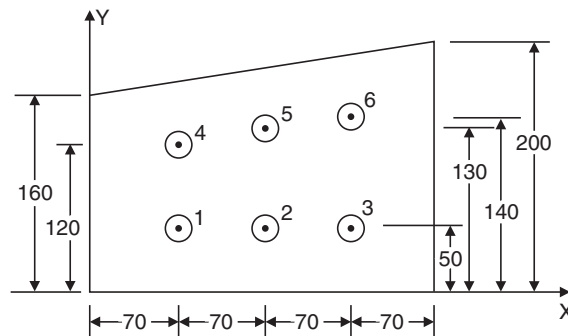

Fig. 4.34

Solution: The composite area is equal to a rectangle of size 160 × 280 mm plus a triangle of size 280 mm base width and 40 mm height and minus areas of six holes. In this case also the Eqn. 4.4 can be used for locating centroid by treating area of holes as negative. The area of simple figures and their centroids are as shown in Table 4.3.

Table 4.3

Figure	Area in mm ²	x _i in mm	y _i in mm
Rectangle	160 × 280 = 44,800	140	80
Triangle	$\frac{1}{2} \times 280 \times 40 = 5600$	$\frac{560}{3}$	$160 + \frac{40}{3} = 173.33$
1st hole	$\frac{-\pi \times 21.5^2}{4} = -363.05$	70	50
2nd hole	-363.05	140	50
3rd hole	-363.05	210	50
4th hole	-363.05	70	120
5th hole	-363.05	140	130
6th hole	-363.05	210	140

$$\therefore A = \Sigma A_i = 48221.70$$

$$\begin{aligned} \therefore \Sigma A_i x_i &= 44800 \times 140 + 5600 \times \frac{560}{3} - 363.05 (70 + 140 + 210 + 70 + 140 + 210) \\ &= 7012371.3 \text{ mm}^3 \end{aligned}$$

$$\bar{x} = \frac{\Sigma A_i x_i}{A} = 145.42 \text{ mm}$$

$$\begin{aligned} \Sigma A_i y_i &= 44800 \times 80 + 5600 \times 173.33 - 363.05 (50 \times 3 + 120 + 130 + 140) \\ &= 4358601 \text{ mm}^3 \end{aligned}$$

$$\begin{aligned} \bar{y} &= \frac{\Sigma A_i y_i}{A} = \frac{4358601}{48221.70} \\ &= 90.39 \text{ mm} \end{aligned}$$

Thus, the coordinates of centroid of composite figure is given by:

$$\bar{x} = 145.42 \text{ mm}$$

$$\bar{y} = 90.39 \text{ mm}$$

Example 4.10. Determine the coordinates x_c and y_c of the centre of a 100 mm diameter circular hole cut in a thin plate so that this point will be the centroid of the remaining shaded area shown in Fig. 4.35 (All dimensions are in mm).

Solution: If x_c and y_c are the coordinates of the centre of the circle, centroid also must have the coordinates x_c and y_c as per the condition laid down in the problem. The shaded area may be considered as a rectangle of size 200 mm × 150 mm minus a triangle of sides 100 mm × 75 mm and a circle of diameter 100 mm.

∴ Total area

$$\begin{aligned} &= 200 \times 150 - \frac{1}{2} \times 100 \times 75 - \left(\frac{\pi}{4}\right) 100^2 \\ &= 18396 \text{ mm}^2 \end{aligned}$$

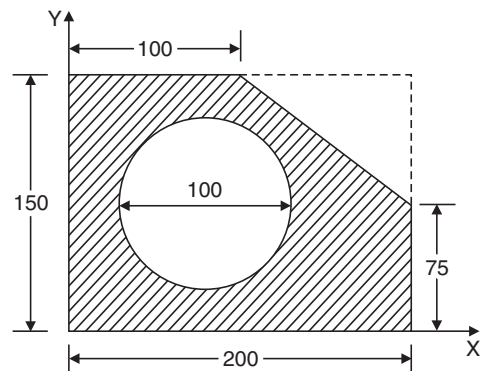

Fig. 4.35

$$x_c = \bar{x} = \frac{200 \times 150 \times 100 - \frac{1}{2} \times 100 \times 75 \times \left[200 - \left(\frac{100}{3} \right) \right] - \frac{\pi}{4} \times 100^2 \times x_c}{18396}$$

$$\therefore x_c(18396) = 200 \times 150 \times 100 - \frac{1}{2} \times 100 \times 75 \times 166.67 - \frac{\pi}{4} \times 100^2 x_c$$

$$x_c = \frac{2375000}{26250} = 90.48 \text{ mm}$$

Similarly,

$$18396 y_c = 200 \times 150 \times 75 - \frac{1}{2} \times 100 \times 75 \times (150 - 25) - \frac{\pi}{4} \times 100^2 y_c$$

$$\therefore y_c = \frac{1781250.0}{26250} = 67.86 \text{ mm}$$

Centre of the circle should be located at (90.48, 67.86) so that this point will be the centroid of the remaining shaded area as shown in Fig. 4.35.

Note: The centroid of the given figure will coincide with the centroid of the figure without circular hole. Hence, the centroid of the given figure may be obtained by determining the centroid of the figure without the circular hole also.

Example 4.11. Determine the coordinates of the centroid of the plane area shown in Fig. 4.36 with reference to the axis shown. Take $x = 40 \text{ mm}$.

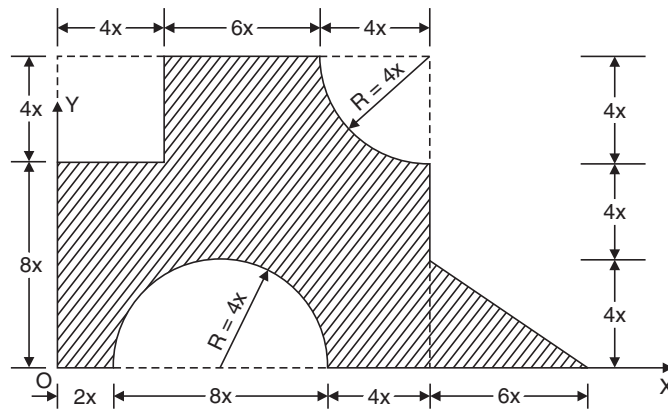

Fig. 4.36

Solution: The composite figure is divided into the following simple figures:

- (1) A rectangle $A_1 = (14x) \times (12x) = 168x^2$
 $x_1 = 7x; y_1 = 6x$

(2) A triangle $A_2 = \frac{1}{2} (6x) \times (4x) = 12x^2$
 $x_2 = 14x + 2x = 16x$
 $y_2 = \frac{4x}{3}$

(3) A rectangle to be subtracted
 $A_3 = (-4x) \times (4x) = -16x^2$
 $x_3 = 2x; y_3 = 8x + 2x = 10x$

(4) A semicircle to be subtracted
 $A_4 = -\frac{1}{2} \pi (4x)^2 = -8\pi x^2$
 $x_4 = 6x$
 $y_4 = \frac{4R}{3\pi} = 4 \times \frac{4(x)}{3\pi} = \frac{16x}{3\pi}$

(5) A quarter of a circle to be subtracted
 $A_5 = -\frac{1}{4} \times \pi (4x)^2 = -4\pi x^2$

$$x_5 = 14x - \frac{4R}{3\pi} = 14x - (4) \left(\frac{4x}{3\pi} \right) = 12.3023x$$

$$y_5 = 12x - 4 \times \left(\frac{4x}{3\pi} \right) = 10.3023x$$

Total area $A = 168x^2 + 12x^2 - 16x^2 - 8\pi x^2 - 4\pi x^2$
 $= 126.3009x^2$

$$\bar{x} = \frac{\Sigma A_i x_i}{A}$$

$$\Sigma A_i x_i = 168x^2 \times 7x + 12x^2 \times 16x - 16x^2 \times 2x - 8\pi x^2 \times 6x - 4\pi x^2 \times 12.3023x$$

$$= 1030.6083x^3$$

$\therefore \bar{x} = \frac{1030.6083x^3}{126.3009x^2}$
 $= 8.1599x = 8.1599 \times 40$ (since $x = 40$ mm)
 $= \mathbf{326.40 \text{ mm}}$

$$\bar{y} = \frac{\Sigma A_i y_i}{A}$$

$$\begin{aligned} \Sigma A_i y_i &= 168x^2 \times 6x + 12x^2 \times \frac{4x}{3} - 16x^2 \times 10x \\ &\quad - 8\pi x^2 \times \frac{16x}{3\pi} - 4\pi x^2 \times 10.3023x \\ &= 691.8708x^3 \\ \therefore \bar{y} &= \frac{691.8708x^3}{126.3009x^2} \\ &= 5.4780x \\ &= \mathbf{219.12 \text{ mm}} \quad (\text{since } x = 40 \text{ mm}) \end{aligned}$$

Centroid is at (326.40, 219.12).

4.5 SECOND MOMENTS OF PLANE AREA

Consider the area shown in Fig. 4.37(a). dA is an elemental area with coordinates as x and y . The term $\Sigma y_i^2 dA_i$ is called *moment of inertia* of the area about x axis and is denoted as I_{xx} . Similarly, the moment of inertia about y axis is

$$I_{yy} = \Sigma x_i^2 dA_i$$

In general, if r is the distance of elemental area dA from the axis AB [Fig. 4.37(b)], the sum of the terms $\Sigma r^2 dA$ to cover the entire area is called moment of inertia of the area about the axis AB . If r and dA can be expressed in general term, for any element, then the sum becomes an integral. Thus,

$$I_{AB} = \Sigma r_i^2 dA_i = \int r^2 dA \quad \dots(4.6)$$

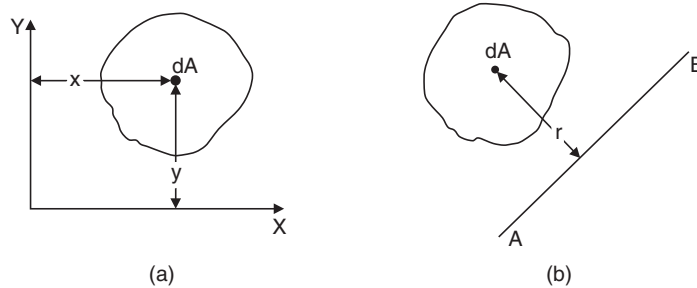

Fig. 4.37

The term rdA may be called as moment of area, similar to moment of a force, and hence $r^2 dA$ may be called as moment of area or the second moment of area. Thus, the moment of inertia of area is nothing but second moment of area. In fact, the term ‘*second moment of area*’ appears to correctly signify the meaning of the expression $\Sigma r^2 dA$. The term ‘moment of inertia’ is rather a misnomer. However, the term moment of inertia has come to stay for long time and hence it will be used in this book also.

Though moment of inertia of plane area is a purely mathematical term, it is one of the important properties of areas. The strength of members subject to bending depends on the moment of inertia of its cross-sectional area. Students will find this property of area very useful when they study subjects like strength of materials, structural design and machine design.

The moment of inertia is a fourth dimensional term since it is a term obtained by multiplying area by the square of the distance. Hence, in SI units, if metre (m) is the unit for linear measurements

used then m^4 is the unit of moment of inertia. If millimetre (mm) is the unit used for linear measurements, then mm^4 is the unit of moment of inertia. In MKS system m^4 or cm^4 and in FPS system ft^4 or in^4 are commonly used as units for moment of inertia.

Polar Moment of Inertia

Moment of inertia about an axis perpendicular to the plane of an area is known as *polar moment of inertia*. It may be denoted as J or I_{zz} . Thus, the moment of inertia about an axis perpendicular to the plane of the area at O in Fig. 4.38 is called polar moment of inertia at point O , and is given by

$$I_{zz} = \Sigma r^2 dA \quad \dots(4.7)$$

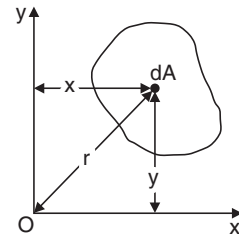

Fig. 4.38

Radius of Gyration

Radius of gyration is a mathematical term defined by the relation

$$k = \sqrt{\frac{I}{A}} \quad \dots(4.8)$$

where k = radius of gyration,

I = moment of inertia,

and A = the cross-sectional area

Suffixes with moment of inertia I also accompany the term radius of gyration k . Thus, we can have,

$$k_{xx} = \sqrt{\frac{I_{xx}}{A}}$$

$$k_{yy} = \sqrt{\frac{I_{yy}}{A}}$$

$$k_{AB} = \sqrt{\frac{I_{AB}}{A}}$$

and so on.

The relation between radius of gyration and moment of inertia can be put in the form:

$$I = Ak^2 \quad \dots(4.9)$$

From the above relation a geometric meaning can be assigned to the term 'radius of gyration.' We can consider k as the distance at which the complete area is squeezed and kept as a strip of negligible width (Fig. 4.39) such that there is no change in the moment of inertia.

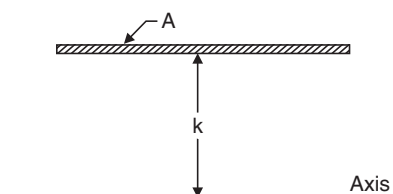

Fig. 4.39

Theorems of Moments of Inertia

There are two theorems of moment of inertia:

- (1) Perpendicular axis theorem, and
- (2) Parallel axis theorem.

These are explained and proved below.

Perpendicular Axis Theorem

The moment of inertia of an area about an axis perpendicular to its plane (polar moment of inertia) at any point O is equal to the sum of moments of inertia about any two mutually perpendicular axis through the same point O and lying in the plane of the area.

Referring to Fig. 4.40, if $z-z$ is the axis normal to the plane of paper passing through point O , as per this theorem,

$$I_{zz} = I_{xx} + I_{yy} \quad \dots (4.10)$$

The above theorem can be easily proved. Let us consider an elemental area dA at a distance r from O . Let the coordinates of dA be x and y . Then from definition:

$$\begin{aligned} I_{zz} &= \Sigma r^2 dA \\ &= \Sigma (x^2 + y^2) dA \\ &= \Sigma x^2 dA + \Sigma y^2 dA \end{aligned}$$

$$I_{zz} = I_{xx} + I_{yy}$$

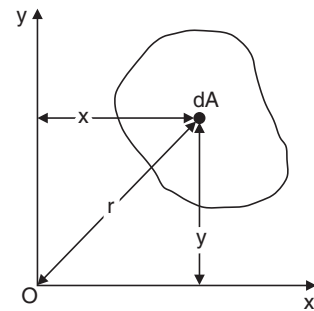

Fig. 4.40

Parallel Axis Theorem

Moment of inertia about any axis in the plane of an area is equal to the sum of moment of inertia about a parallel centroidal axis and the product of area and square of the distance between the two parallel axis. Referring to Fig. 4.41 the above theorem means:

$$I_{AB} = I_{GG} + A y_c^2 \quad \dots(4.11)$$

where

I_{AB} = moment of inertia about axis AB

I_{GG} = moment of inertia about centroidal axis GG parallel to AB .

A = the area of the plane figure given and

y_c = the distance between the axis AB and the parallel centroidal axis GG .

Proof: Consider an elemental parallel strip dA at a distance y from the centroidal axis (Fig. 4.41).

Then,

$$\begin{aligned} I_{AB} &= \Sigma (y + y_c)^2 dA \\ &= \Sigma (y^2 + 2y y_c + y_c^2) dA \\ &= \Sigma y^2 dA + \Sigma 2y y_c dA + \Sigma y_c^2 dA \end{aligned}$$

Now,

$$\begin{aligned} \Sigma y^2 dA &= \text{Moment of inertia about the axis } GG \\ &= I_{GG} \end{aligned}$$

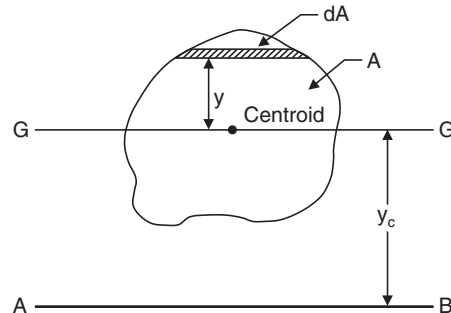

Fig. 4.41

$$\begin{aligned}\Sigma 2yy_c dA &= 2y_c \Sigma y dA \\ &= 2y_c A \frac{\Sigma ydA}{A}\end{aligned}$$

In the above term $2y_c A$ is constant and $\frac{\Sigma ydA}{A}$ is the distance of centroid from the reference axis GG . Since GG is passing through the centroid itself $\frac{ydA}{A}$ is zero and hence the term $\Sigma 2yy_c dA$ is zero.

Now, the third term,

$$\begin{aligned}\Sigma y_c^2 dA &= y_c^2 \Sigma dA \\ &= Ay_c^2 \\ \therefore I_{AB} &= I_{GG} + Ay_c^2\end{aligned}$$

Note: The above equation cannot be applied to any two parallel axis. One of the axis (GG) must be centroidal axis only.

4.6 MOMENT OF INERTIA FROM FIRST PRINCIPLES

For simple figures, moment of inertia can be obtained by writing the general expression for an element and then carrying out integration so as to cover the entire area. This procedure is illustrated with the following three cases:

- (1) Moment of inertia of a rectangle about the centroidal axis
- (2) Moment of inertia of a triangle about the base
- (3) Moment of inertia of a circle about a diametral axis

(1) *Moment of Inertia of a Rectangle about the Centroidal Axis:* Consider a rectangle of width b and depth d (Fig. 4.42). Moment of inertia about the centroidal axis $x-x$ parallel to the short side is required.

Consider an elemental strip of width dy at a distance y from the axis. Moment of inertia of the elemental strip about the centroidal axis xx is:

$$\begin{aligned}&= y^2 dA \\ &= y^2 b dy \\ \therefore I_{xx} &= \int_{-d/2}^{d/2} y^2 b dy \\ &= b \left[\frac{y^3}{3} \right]_{-d/2}^{d/2} \\ &= b \left[\frac{d^3}{24} + \frac{d^3}{24} \right] \\ I_{xx} &= \frac{bd^3}{12}\end{aligned}$$

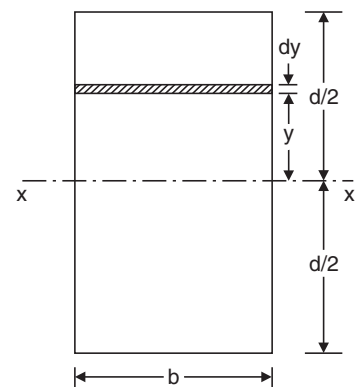

Fig. 4.42

(2) *Moment of Inertia of a Triangle about its Base:* Moment of inertia of a triangle with base width b and height h is to be determined about the base AB (Fig. 4.43).

Consider an elemental strip at a distance y from the base AB . Let dy be the thickness of the strip and dA its area. Width of this strip is given by:

$$b_1 = \frac{(h - y)}{h} \times b$$

$$\begin{aligned} \text{Moment of inertia of this strip about } AB &= y^2 dA \\ &= y^2 b_1 dy \\ &= y^2 \frac{(h - y)}{h} \times b \times dy \end{aligned}$$

∴ Moment of inertia of the triangle about AB ,

$$\begin{aligned} I_{AB} &= \int_0^h \frac{y^2 (h - y) b dy}{h} \\ &= \int_0^h \left(y^2 - \frac{y^3}{h} \right) b dy \\ &= b \left[\frac{y^3}{3} - \frac{y^4}{4h} \right]_0^h \\ &= b \left[\frac{h^3}{3} - \frac{h^4}{4h} \right] \\ I_{AB} &= \frac{bh^3}{12} \end{aligned}$$

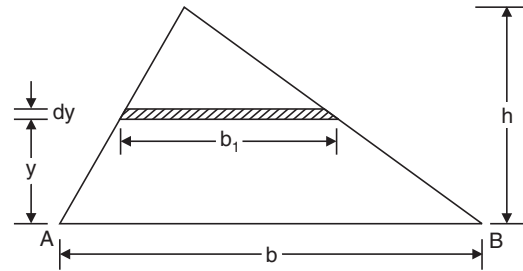

Fig. 4.43

(3) *Moment of Inertia of a Circle about its Diametral Axis:* Moment of inertia of a circle of radius R is required about its diametral axis as shown in Fig. 4.44

Consider an element of sides $rd\theta$ and dr as shown in the figure. Its moment of inertia about the diametral axis $x-x$:

$$\begin{aligned} &= y^2 dA \\ &= (r \sin \theta)^2 r d\theta dr \\ &= r^3 \sin^2 \theta d\theta dr \end{aligned}$$

∴ Moment of inertia of the circle about $x-x$ is given by

$$I_{xx} = \int_0^R \int_0^{2\pi} r^3 \sin^2 \theta d\theta dr$$

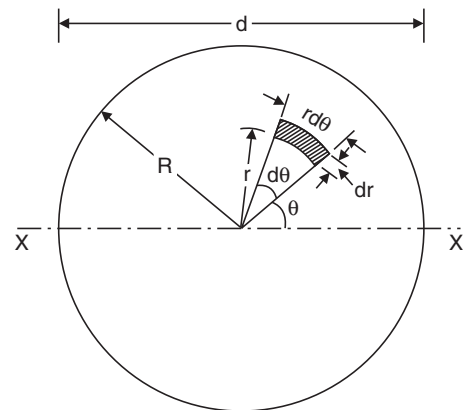

Fig. 4.44

$$\begin{aligned}
 &= \int_0^R \int_0^{2\pi} \frac{(1 - \cos 2\theta)}{2} d\theta dr \\
 &= \int_0^R \frac{r^3}{2} \left[\theta - \frac{\sin 2\theta}{2} \right]_0^{2\pi} dr \\
 &= \left[\frac{r^4}{8} \right]_0^R [2\pi - 0 + 0 - 0] = \frac{2\pi}{8} R^4
 \end{aligned}$$

$$I_{xx} = \frac{\pi R^4}{4}$$

If d is the diameter of the circle, then

$$R = \frac{d}{2}$$

$$\therefore I_{xx} = \frac{\pi}{4} \left(\frac{d}{2} \right)^4$$

$$I_{xx} = \frac{\pi d^4}{64}$$

Moment of Inertia of Standard Sections

Rectangle: Referring to Fig. 4.45.

(a) $I_{xx} = \frac{bd^3}{12}$ as derived from first principle.

(b) $I_{yy} = \frac{db^3}{12}$ can be derived on the same lines.

(c) About the base AB , from parallel axis theorem,

$$\begin{aligned}
 I_{AB} &= I_{xx} + Ay_c^2 \\
 &= \frac{bd^3}{12} + bd \left(\frac{d}{2} \right)^2, \quad \text{since } y_c = \frac{d}{2}
 \end{aligned}$$

$$= \frac{bd^3}{12} + \frac{bd^3}{4}$$

$$= \frac{bd^3}{3}$$

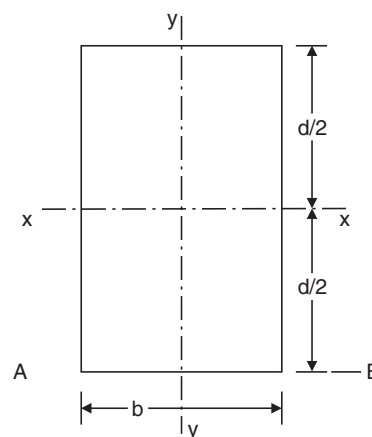

Fig. 4.45

Hollow Rectangular Section: Referring to Fig. 4.46, Moment of inertia I_{xx} = Moment of inertia of larger rectangle–Moment of inertia of hollow portion. That is,

$$= \frac{BD^3}{12} - \frac{bd^3}{12}$$

$$= \frac{1}{12}(BD^3 - bd^3)$$

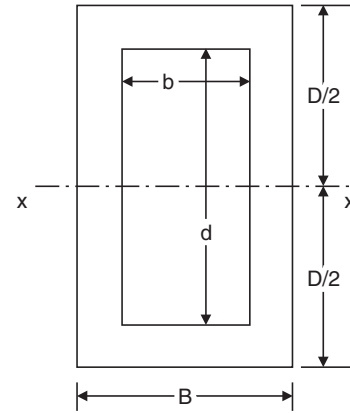

Fig. 4.46

Triangle—Referring to Fig. 4.47.

(a) *About the base:*

As found from first principle

$$I_{AB} = \frac{bh^3}{12}$$

(b) *About centroidal axis, x-x parallel to base:*

From parallel axis theorem,

$$I_{AB} = I_{xx} + Ay_c^2$$

Now, y_c , the distance between the non-centroidal axis AB and centroidal axis x-x, is equal to $\frac{h}{3}$.

$$\therefore \frac{bh^3}{12} = I_{xx} + \frac{1}{2}bh\left(\frac{h}{3}\right)^2$$

$$= I_{xx} + \frac{bh^3}{18}$$

$$\therefore I_{xx} = \frac{bh^3}{12} - \frac{bh^3}{18}$$

$$= \frac{bh^3}{36}$$

Moment of Inertia of a Circle about any diametral axis

$$= \frac{\pi d^4}{64} \quad (\text{as found from first principle})$$

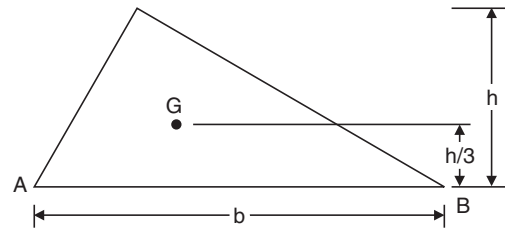

Fig. 4.47

Moment of Inertia of a Hollow Circle: Referring to Fig. 4.48.

I_{AB} = Moment of inertia of solid circle of diameter D about AB

– Moment of inertia of circle of diameter d about AB . That is,

$$\begin{aligned} &= \frac{\pi D^4}{64} - \frac{\pi d^4}{64} \\ &= \frac{\pi}{64} (D^4 - d^4) \end{aligned}$$

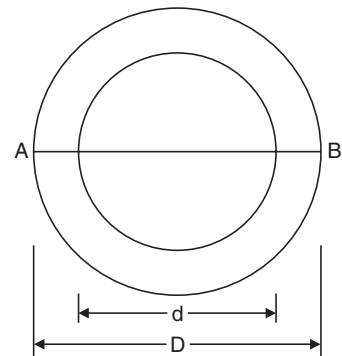

Fig. 4.48

Moment of Inertia of a Semicircle: (a) About Diametral Axis:

If the limit of integration is put as 0 to π instead of 0 to 2π in the derivation for the moment of inertia of a circle about diametral axis the moment of inertia of a semicircle is obtained. It can be observed that the moment of inertia of a semicircle (Fig. 4.49) about the diametral axis AB :

$$= \frac{1}{2} \times \frac{\pi d^4}{64} = \frac{\pi d^4}{128}$$

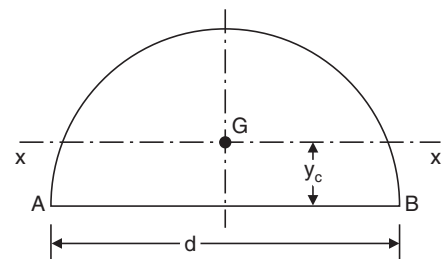

Fig. 4.49

(b) *About Centroidal Axis $x-x$:*

Now, the distance of centroidal axis y_c from the diametral axis is given by:

$$y_c = \frac{4R}{3\pi} = \frac{2d}{3\pi}$$

and,
$$\text{Area } A = \frac{1}{2} \times \frac{\pi d^2}{4} = \frac{\pi d^2}{8}$$

From parallel axis theorem,

$$\begin{aligned} I_{AB} &= I_{xx} + Ay_c^2 \\ \frac{\pi d^4}{128} &= I_{xx} + \frac{\pi d^2}{8} \times \left(\frac{2d}{3\pi}\right)^2 \end{aligned}$$

$$\begin{aligned} I_{xx} &= \frac{\pi d^4}{128} - \frac{d^4}{18\pi} \\ &= 0.0068598 d^4 \end{aligned}$$

Moment of Inertia of a Quarter of a Circle: (a) About the Base: If the limit of integration is put as 0 to $\frac{\pi}{2}$ instead of 0 to 2π in the derivation for moment of inertia of a circle the moment of inertia of a quarter of a circle is obtained. It can be observed that moment of inertia of the quarter of a circle about the base AB .

$$= \frac{1}{4} \times \frac{\pi d^4}{64\pi} = \frac{\pi d^4}{256}$$

(b) About Centroidal Axis $x-x$:

Now, the distance of centroidal axis y_c from the base is given by:

$$y_c = \frac{4R}{3\pi} = \frac{2d}{3\pi}$$

and the area $A = \frac{1}{4} \times \frac{\pi d^2}{4} = \frac{\pi d^2}{16}$

From parallel axis theorem,

$$I_{AB} = I_{xx} + Ay_c^2$$

$$\frac{\pi d^4}{256} = I_{xx} + \frac{\pi d^2}{16} \left(\frac{2d}{3\pi}\right)^2$$

$$I_{xx} = \frac{\pi d^4}{256} - \frac{d^4}{36\pi}$$

$$= 0.00343 d^4$$

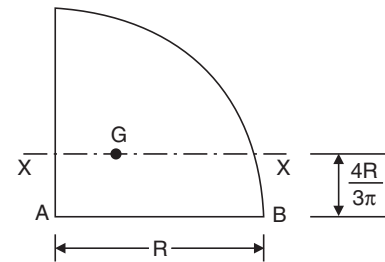

Fig. 4.50

The moment of inertia of common standard sections are presented in Table 4.4.

Table 4.4 Moment of Inertia of Standard Sections

Shape	Axis	Moment of Inertia
Rectangle 	(a) Centroidal axis $x-x$	$I_{xx} = \frac{bd^3}{12}$
	(b) Centroidal axis $y-y$	$I_{yy} = \frac{db^3}{12}$
	(c) $A - B$	$I_{AB} = \frac{bd^3}{3}$
Hollow Rectangle 	Centroidal axis $x-x$	$I_{xx} = \frac{BD^3 - bd^3}{12}$

(Contd.)

Table 4.4 (Contd.)

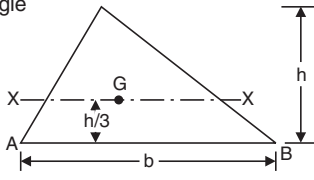
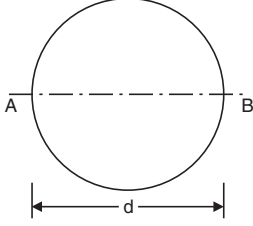
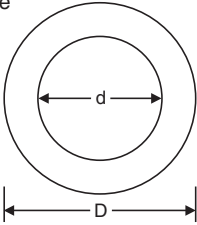
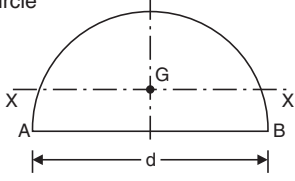
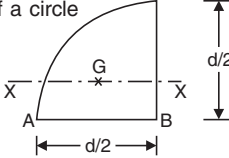
Shape	Axis	Moment of Inertia
<p>Triangle</p> 	<p>(a) Centroidal axis $x-x$</p> <p>(b) Base AB</p>	$I_{xx} = \frac{bh^3}{36}$ $I_{AB} = \frac{bh^3}{12}$
<p>Circle</p> 	Diametral axis	$I = \frac{\pi d^4}{64}$
<p>Hollow circle</p> 	Diametral axis	$I = \frac{\pi}{64} (D^4 - d^4)$
<p>Semicircle</p> 	<p>(a) $A - B$</p> <p>(b) Centroidal axis</p>	$I_{AB} = \frac{\pi d^4}{128}$ $I_{xx} = 0.0068598 d^4$
<p>Quarter of a circle</p> 	<p>(a) $A - B$</p> <p>(b) Centroidal axis $x-x$</p>	$I_{AB} = \frac{\pi d^4}{256}$ $I_{xx} = 0.00343 d^4$

4.7 MOMENT OF INERTIA OF COMPOSITE SECTIONS

Beams and columns having composite sections are commonly used in structures. Moment of inertia of these sections about an axis can be found by the following steps:

- (1) Divide the given figure into a number of simple figures.
- (2) Locate the centroid of each simple figure by inspection or using standard expressions.
- (3) Find the moment of inertia of each simple figure about its centroidal axis. Add the term Ay^2 where A is the area of the simple figure and y is the distance of the centroid of the simple figure from the reference axis. This gives moment of inertia of the simple figure about the reference axis.
- (4) Sum up moments of inertia of all simple figures to get the moment of inertia of the composite section.

The procedure given above is illustrated below. Referring to the Fig. 4.51, it is required to find out the moment of inertia of the section about axis $A-B$.

(1) The section in the figure is divided into a rectangle, a triangle and a semicircle. The areas of the simple figures A_1 , A_2 and A_3 are calculated.

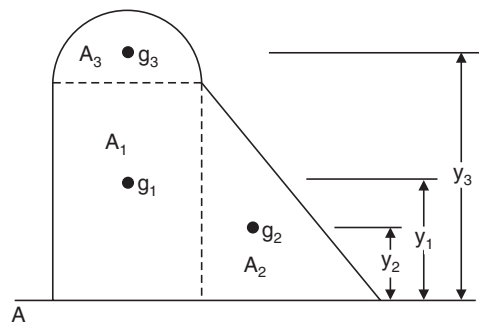

Fig. 4.51

(2) The centroids of the rectangle (g_1), triangle (g_2) and semicircle (g_3) are located. The distances y_1 , y_2 and y_3 are found from the axis AB .

(3) The moment of inertia of the rectangle about its centroid (I_{g_1}) is calculated using standard expression. To this, the term $A_1 y_1^2$ is added to get the moment of inertia about the axis AB as:

$$I_1 = I_{g_1} + A_1 y_1^2$$

Similarly, the moment of inertia of the triangle ($I_2 = I_{g_2} + A_2 y_2^2$) and of semicircle ($I_3 = I_{g_3} + A_3 y_3^2$) about axis AB are calculated.

(4) Moment of inertia of the composite section about AB is given by:

$$\begin{aligned} I_{AB} &= I_1 + I_2 + I_3 \\ &= I_{g_1} + A_1 y_1^2 + I_{g_2} + A_2 y_2^2 + I_{g_3} + A_3 y_3^2 \end{aligned} \quad \dots(4.12)$$

In most engineering problems, moment of inertia about the centroidal axis is required. In such cases, first locate the centroidal axis as discussed in 4.4 and then find the moment of inertia about this axis.

Referring to Fig. 4.52, first the moment of area about any reference axis, say AB is taken and is divided by the total area of section to locate centroidal axis $x-x$. Then the distances of centroid of

individual figures y_{c1} , y_{c2} and y_{c3} from the axis $x-x$ are determined. The moment of inertia of the composite section about the centroidal axis $x-x$ is calculated using the expression:

$$I_{xx} = I_{g_1} + A_1^2 y_{c1} + I_{g_2} + A_2^2 y_{c2} + I_{g_3} + A_3^2 y_{c3} \quad \dots(4.13)$$

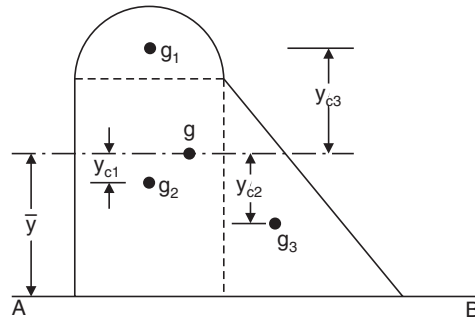

Fig. 4.52

Sometimes the moment of inertia is found about a convenient axis and then using parallel axis theorem, the moment of inertia about centroidal axis is found.

In the above example, the moment of inertia I_{AB} is found and y_c , the distance of CG from axis AB is calculated. Then from parallel axis theorem,

$$I_{AB} = I_{xx} + Ay_c^2$$

$$I_{xx} = I_{AB} - Ay_c^2$$

where A is the area of composite section.

Example 4.12. Determine the moment of inertia of the section shown in Fig. 4.53 about an axis passing through the centroid and parallel to the top most fibre of the section. Also determine moment of inertia about the axis of symmetry. Hence find radii of gyration.

Solution: The given composite section can be divided into two rectangles as follows:

$$\text{Area } A_1 = 150 \times 10 = 1500 \text{ mm}^2$$

$$\text{Area } A_2 = 140 \times 10 = 1400 \text{ mm}^2$$

$$\text{Total Area } A = A_1 + A_2 = 2900 \text{ mm}^2$$

Due to symmetry, centroid lies on the symmetric axis $y-y$.

The distance of the centroid from the top most fibre is given by:

$$\begin{aligned} y_c &= \frac{\text{Sum of moment of the areas about the top most fibre}}{\text{Total area}} \\ &= \frac{1500 \times 5 + 1400(10 + 70)}{2900} \\ &= 41.21 \text{ mm} \end{aligned}$$

Referring to the centroidal axis $x-x$ and $y-y$, the centroid of A_1 is $g_1(0.0, 36.21)$ and that of A_2 is $g_2(0.0, 38.79)$.

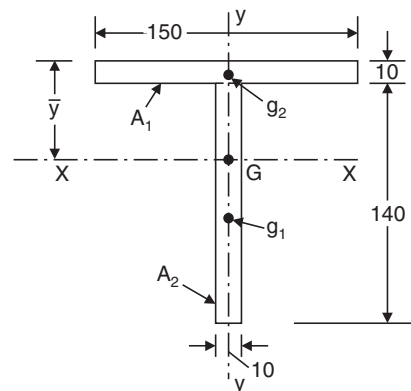

Fig. 4.53

Moment of inertia of the section about $x-x$ axis

I_{xx} = moment of inertia of A_1 about $x-x$ axis + moment of inertia of A_2 about $x-x$ axis.

$$\therefore I_{xx} = \frac{150 \times 10^3}{12} + 1500 (36.21)^2 + \frac{10 \times 140^3}{12} + 1400 (38.79)^2$$

i.e., $I_{xx} = 63\,72442.5 \text{ mm}^4$

Similarly,

$$I_{yy} = \frac{10 \times 150^3}{12} + \frac{140 \times 10^3}{12} = 2824,166.7 \text{ mm}^4$$

Hence, the moment of inertia of the section about an axis passing through the centroid and parallel to the top most fibre is 6372442.5 mm^4 and moment of inertia of the section about the axis of symmetry is 2824166.66 mm^4 .

The radius of gyration is given by:

$$k = \sqrt{\frac{I}{A}}$$

$$\therefore k_{xx} = \sqrt{\frac{I_{xx}}{A}}$$

$$= \sqrt{\frac{6372442.5}{2900}}$$

$$k_{xx} = 46.88 \text{ mm}$$

Similarly, $k_{yy} = \sqrt{\frac{2824166.66}{2900}}$

$$k_{yy} = 31.21 \text{ mm}$$

Example 4.13. Determine the moment of inertia of the L-section shown in the Fig. 4.54 about its centroidal axis parallel to the legs. Also find out the polar moment of inertia.

Solution: The given section is divided into two rectangles A_1 and A_2 .

$$\text{Area } A_1 = 125 \times 10 = 1250 \text{ mm}^2$$

$$\text{Area } A_2 = 75 \times 10 = 750 \text{ mm}^2$$

$$\text{Total Area} = 2000 \text{ mm}^2$$

First, the centroid of the given section is to be located.

Two reference axis (1)–(1) and (2)–(2) are chosen as shown in Fig. 4.54.

The distance of centroid from the axis (1)–(1)

$$= \frac{\text{sum of moment of areas } A_1 \text{ and } A_2 \text{ about (1)–(1)}}{\text{Total area}}$$

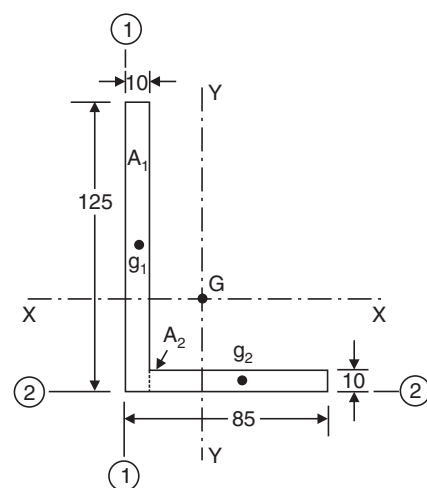

Fig. 4.54

$$\begin{aligned} \text{i.e., } \bar{x} &= \frac{120 \times 5 + 750 \left(10 + \frac{75}{2}\right)}{2000} \\ &= 20.94 \text{ mm} \end{aligned}$$

Similarly,

the distance of the centroid from the axis (2)–(2)

$$\bar{y} = \frac{1250 \times \frac{125}{2} + 750 \times 5}{2000} = 40.94 \text{ mm}$$

With respect to the centroidal axis $x-x$ and $y-y$, the centroid of A_1 is g_1 (15.94, 21.56) and that of A_2 is g_2 (26.56, 35.94).

$\therefore I_{xx}$ = Moment of inertia of A_1 about $x-x$ axis + Moment of inertia of A_2 about $x-x$ axis

$$\therefore I_{xx} = \frac{10 \times 125^3}{12} + 1250 \times 21.56^2 + \frac{75 \times 10^3}{12} + 750 \times 39.94^2$$

$$\text{i.e., } I_{xx} = 3411298.9 \text{ mm}^4$$

Similarly,

$$I_{yy} = \frac{125 \times 10^3}{12} + 1250 \times 15.94^2 + \frac{10 \times 75^3}{12} + 750 \times 26.56^2$$

$$\text{i.e., } I_{yy} = 1208658.9 \text{ mm}^4$$

$$\begin{aligned} \text{Polar moment of inertia} &= I_{xx} + I_{yy} \\ &= 3411298.9 + 12,08658.9 \end{aligned}$$

$$I_{zz} = 4619957.8 \text{ mm}^4$$

Example 14. Determine the moment of inertia of the symmetric I-section shown in Fig. 4.55 about its centroidal axis $x-x$ and $y-y$.

Also, determine moment of inertia of the section about a centroidal axis perpendicular to $x-x$ axis and $y-y$ axis.

Solution: The section is divided into three rectangles A_1 , A_2 and A_3 .

$$\text{Area } A_1 = 200 \times 9 = 1800 \text{ mm}^2$$

$$\text{Area } A_2 = (250 - 9 \times 2) \times 6.7 = 1554.4 \text{ mm}^2$$

$$\text{Area } A_3 = 200 \times 9 = 1800 \text{ mm}^2$$

$$\text{Total Area } A = 5154.4 \text{ mm}^2$$

The section is symmetrical about both $x-x$ and $y-y$ axis. Therefore, its centroid will coincide with the centroid of rectangle A_2 .

With respect to the centroidal axis $x-x$ and $y-y$, the centroid of rectangle A_1 is g_1 (0.0, 120.5), that of A_2 is g_2 (0.0, 0.0) and that of A_3 is g_3 (0.0, 120.5).

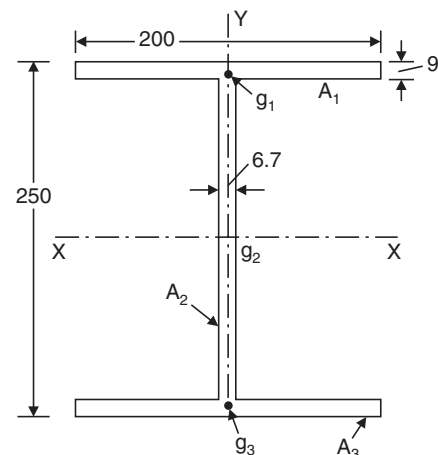

Fig. 4.55

I_{xx} = Moment of inertia of A_1 + Moment of inertia of A_2
 + Moment of inertia of A_3 about x - x axis

$$I_{xx} = \frac{200 \times 9^3}{12} + 1800 \times 120.5^2 + \frac{6.7 \times 232^3}{12} + 0$$

$$+ \frac{200 \times 9^3}{12} + 1800(120.5)^2$$

$I_{xx} = 5,92,69,202 \text{ mm}^4$

Similarly,

$$I_{yy} = \frac{9 \times 200^3}{12} + \frac{232 \times 6.7^3}{12} + \frac{9 \times 200^3}{12}$$

$I_{yy} = 1,20,05,815 \text{ mm}^4$

Moment of inertia of the section about a centroidal axis perpendicular to x - x and y - y axis is nothing but polar moment of inertia, and is given by:

$$I_{xx} = I_{xx} + I_{yy}$$

$$= 59269202 + 12005815$$

$I_{yy} = 7,12,75,017 \text{ mm}^4$

Example 4.15. Compute the second moment of area of the channel section shown in Fig. 4.56 about centroidal axis x - x and y - y .

Solution: The section is divided into three rectangles A_1 , A_2 and A_3 .

- Area $A_1 = 100 \times 13.5 = 1350 \text{ mm}^2$
- Area $A_2 = (400 - 27) \times 8.1 = 3021.3 \text{ mm}^2$
- Area $A_3 = 100 \times 13.5 = 1350.00 \text{ mm}^2$
- Total Area $A = 5721.3 \text{ mm}^2$

The given section is symmetric about horizontal axis passing through the centroid g_2 of the rectangle A_2 . A reference axis (1)–(1) is chosen as shown in Fig. 4.56.

The distance of the centroid of the section from (1)–(1)

$$= \frac{1350 \times 50 + 3021.3 \times \frac{8.1}{2} + 1350 \times 50}{5721.3}$$

$$= 25.73 \text{ mm}$$

With reference to the centroidal axis x - x and y - y , the centroid of the rectangle A_1 is $g_1(24.27, 193.25)$ that of A_2 is $g_2(21.68, 0.0)$ and that of A_3 is $g_3(24.27, 193.25)$.

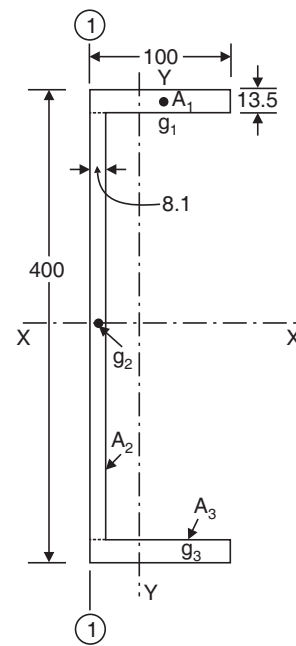

Fig. 4.56

$$\begin{aligned} \therefore I_{xx} &= \text{Moment of inertia of } A_1, A_2 \text{ and } A_3 \text{ about } x-x \\ &= \frac{100 \times 13.5^3}{12} + 1350 \times 193.25^2 \\ &\quad + \frac{8.1 \times 373^3}{12} + \frac{100 \times 13.5^3}{12} + 1350 \times 193.25^2 \\ I_{xx} &= 1.359 \times 10^8 \text{ mm}^4 \end{aligned}$$

$$\begin{aligned} \text{Similarly, } I_{yy} &= \frac{13.5 \times 100^3}{12} + 1350 \times 24.27^2 + \frac{273 \times 8.1^3}{12} + 3021.3 \\ &\quad \times 21.68^2 + \frac{13.5 \times 100^3}{12} + 1350 \times 24.27^2 \\ I_{yy} &= 52,72557.6 \text{ mm}^4 \end{aligned}$$

Example 4.16. Determine the polar moment of inertia of the I-section shown in the Fig. 4.57. Also determine the radii of gyration with respect to x-x axis and y-y axis.

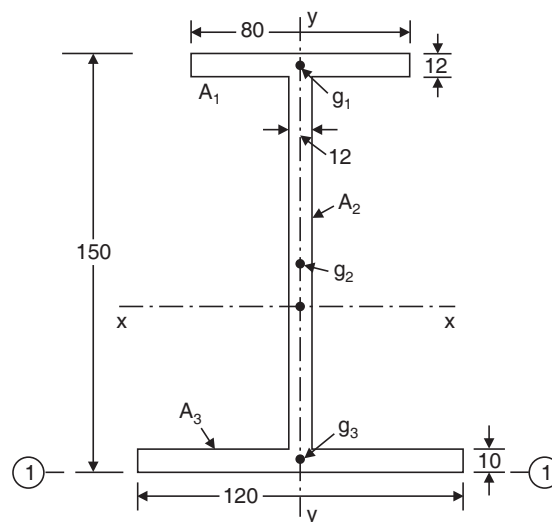

Fig. 4.57

Solution: The section is divided into three rectangles as shown in Fig. 4.57

Area	$A_1 = 80 \times 12 = 960 \text{ mm}^2$
Area	$A_2 = (150 - 22) \times 12 = 1536 \text{ mm}^2$
Area	$A_3 = 120 \times 10 = 1200 \text{ mm}^2$
Total area	$A = 3696 \text{ mm}^2$

Due to symmetry, centroid lies on axis y-y. The bottom fibre (1)–(1) is chosen as reference axis to locate the centroid.

The distance of the centroid from (1)–(1)

$$= \frac{\text{Sum of moments of the areas of the rectangles about (1)–(1)}}{\text{Total area of section}}$$

$$= \frac{960 \times (150 - 6) + 1536 \times \left(\frac{128}{2} + 10\right) + 1200 \times 5}{3696}$$

$$= 69.78 \text{ mm}$$

With reference to the centroidal axis x - x and y - y , the centroid of the rectangles A_1 is g_1 (0.0, 74.22), that of A_2 is g_2 (0.0, 4.22) and that of A_3 is g_3 (0.0, 64.78).

$$I_{xx} = \frac{80 \times 12^3}{12} + 960 \times 74.22^2 + \frac{12 \times 128^3}{12} + 1536 \times 4.22^2 + \frac{120 \times 10^3}{12} + 1200 \times 64.78^2$$

$$I_{xx} = 1,24,70,028 \text{ mm}^4$$

$$I_{yy} = \frac{12 \times 80^3}{12} + \frac{128 \times 12^3}{12} + \frac{10 \times 120^3}{12}$$

$$= 19,70,432 \text{ mm}^4$$

Polar moment of inertia $= I_{xx} + I_{yy}$

$$= 1,24,70,027 + 19,70,432$$

$$= \mathbf{1,44,40459 \text{ mm}^4}$$

$$\therefore k_{xx} = \sqrt{\frac{I_{xx}}{A}} = \sqrt{\frac{1,24,70,027}{3696}}$$

$$= \mathbf{58.09 \text{ mm}}$$

$$k_{yy} = \sqrt{\frac{I_{yy}}{A}} = \sqrt{\frac{19,70,432}{3696}}$$

$$= \mathbf{23.09 \text{ mm.}}$$

Example 4.17. Determine the moment of inertia of the built-up section shown in Fig. 4.58 about its centroidal axis x - x and y - y .

Solution: The given composite section may be divided into simple rectangles and triangles as shown in the Fig. 4.58

Area	$A_1 = 100 \times 30 = 3000 \text{ mm}^2$
Area	$A_2 = 100 \times 25 = 2500 \text{ mm}^2$
Area	$A_3 = 200 \times 20 = 4000 \text{ mm}^2$
Area	$A_4 = \frac{1}{2} \times 87.5 \times 20 = 875 \text{ mm}^2$
Area	$A_5 = \frac{1}{2} \times 87.5 \times 20 = 875 \text{ mm}^2$
Total area	$A = 11250 \text{ mm}^2$

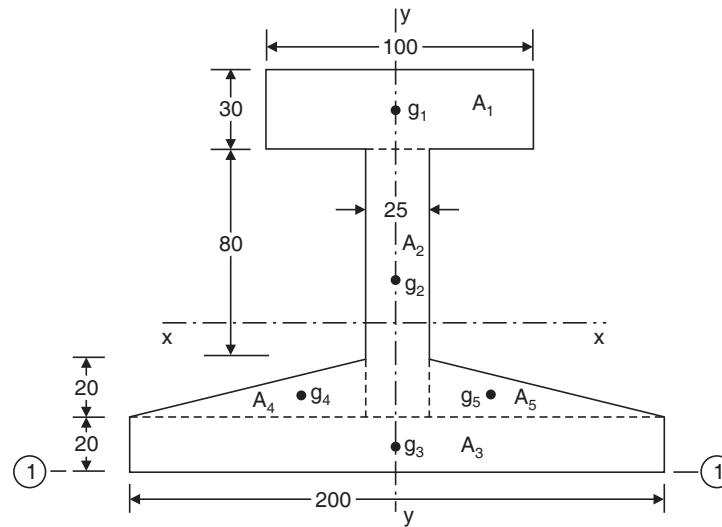

Fig. 4.58

Due to symmetry, centroid lies on the axis y - y .

A reference axis (1)–(1) is chosen as shown in the figure.

The distance of the centroidal axis from (1)–(1)

$$\bar{y} = \frac{\text{sum of moment of areas about (1)–(1)}}{\text{Total area}}$$

$$= \frac{3000 \times 135 + 2500 \times 70 + 4000 \times 10 + 875 \left(\frac{1}{3} \times 20 + 20 \right) \times 2}{11250}$$

$$= 59.26 \text{ mm}$$

With reference to the centroidal axis x - x and y - y , the centroid of the rectangle A_1 is g_1 (0.0, 75.74), that of A_2 is g_2 (0.0, 10.74), that of A_3 is g_3 (0.0, 49.26), the centroid of triangle A_4 is g_4 (41.66, 32.59) and that of A_5 is g_5 (41.66, 32.59).

$$I_{xx} = \frac{100 \times 30^3}{12} + 3000 \times 75.74^2 + \frac{25 \times 100^3}{12} + 2500 \times 10.74^2 + \frac{200 \times 20^3}{12} + 4000$$

$$\times 49.26^2 + \frac{87.5 \times 20^3}{36} + 875 \times 32.59^2 + \frac{87.5 \times 20^3}{36} + 875 \times 32.59^2$$

$$I_{xx} = 3,15,43,447 \text{ mm}^4$$

$$I_{yy} = \frac{30 \times 100^3}{12} + \frac{100 \times 25^3}{12} + \frac{20 \times 200^3}{12} + \frac{20 \times 87.5^3}{36} + 875 \times 41.66^2$$

$$+ \frac{20 \times 87.5^3}{36} + 875 \times 41.66^2$$

$$I_{yy} = 1,97,45,122 \text{ mm}^4.$$

Example 4.18. Determine the moment of inertia of the built-up section shown in the Fig. 4.59 about an axis AB passing through the top most fibre of the section as shown.

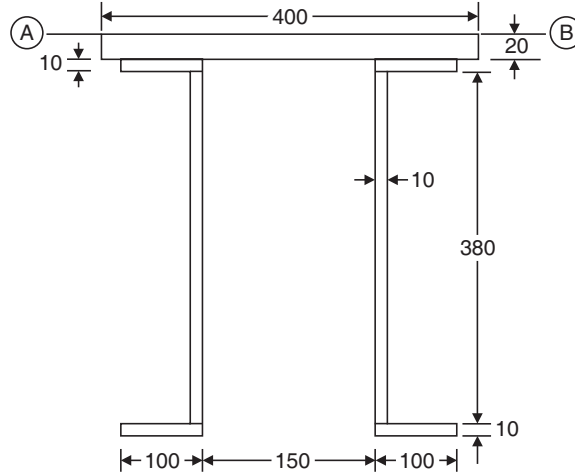

Fig. 4.59

Solution: In this problem, it is required to find out the moment of inertia of the section about an axis AB. So there is no need to find out the position of the centroid.

The given section is split up into simple rectangles as shown in Fig. 4.59.

Now,

Moment of inertia about AB = Sum of moments of inertia of the rectangle about AB

$$\begin{aligned}
 &= \frac{400 \times 20^3}{12} + 400 \times 20 \times 10^2 + \left[\frac{100 \times 10^3}{12} + 100 \times 10 \times (20 + 5)^2 \right] \times 2 \\
 &\quad + \left[\frac{100 \times 380^3}{12} + 10 \times 380 \times (30 + 190)^2 \right] \times 2 \\
 &\quad + \left[\frac{100 \times 10^3}{12} + 100 \times 10 \times (20 + 10 + 380 + 5)^2 \right] \times 2
 \end{aligned}$$

$$I_{AB} = 8.06093 \times 10^8 \text{ mm}^4.$$

Example 4.19. Calculate the moment of inertia of the built-up section shown in Fig. 4.60 about a centroidal axis parallel to AB. All members are 10 mm thick.

Solution: The built-up section is divided into six simple rectangles as shown in the figure.

The distance of centroidal axis from AB

$$\begin{aligned}
 &= \frac{\text{Sum of the moment of areas about AB}}{\text{Total area}} \\
 &= \frac{\sum A_i y_i}{A}
 \end{aligned}$$

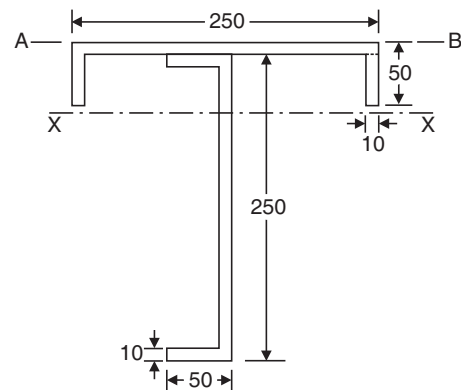

Fig. 4.60

Now,

$$\begin{aligned}\Sigma A_i y_i &= 250 \times 10 \times 5 + 2 \times 40 \times 10 \times (10 + 20) + 40 \times 10 \times (10 + 5) \\ &\quad + 40 \times 10 \times 255 + 250 \times 10 \times (10 + 125) \\ &= 4,82,000 \text{ mm}^3 \\ A &= 2 \times 250 \times 10 + 40 \times 10 \times 4 \\ &= 6600 \text{ mm}^2 \\ \therefore \bar{y} &= \frac{\Sigma A_i y_i}{A} = \frac{482000}{6600} \\ &= 73.03 \text{ mm}\end{aligned}$$

Now,

Moment of inertia about the } = { Sum of the moment of inertia
centroidal axis } of the individual rectangles

$$\begin{aligned} &= \frac{250 \times 10^3}{12} + 250 \times 10 \times (73.03 - 5)^2 \\ &\quad + \left[\frac{10 \times 40^3}{12} + 40 \times 10 (73.03 - 30)^2 \right] \times 2 \\ &\quad + \frac{40 \times 10^3}{12} + 40 \times 10 (73.03 - 15)^2 + \frac{10 \times 250^3}{12} + 250 \\ &\quad \times 10 (73.03 - 135)^2 + \frac{40 \times 10^3}{12} + 40 \times 10 (73.03 - 255)^2 \end{aligned}$$

$$I_{xx} = 5,03,99,395 \text{ mm}^4.$$

Example 4.20. A built-up section of structural steel consists of a flange plate 400 mm × 20 mm, a web plate 600 mm × 15 mm and two angles 150 mm × 150 mm × 10 mm assembled to form a section as shown in Fig. 4.61. Determine the moment of inertia of the section about the horizontal centroidal axis.

Solution: Each angle is divided into two rectangles as shown in Fig. 4.61.

The distance of the centroidal axis from the bottom fibres of section

$$\begin{aligned} &= \frac{\text{Sum of the moment of the areas about bottom fibres}}{\text{Total area of the section}} \\ &= \frac{\Sigma A_i y_i}{A} \end{aligned}$$

Now,

$$\begin{aligned}\Sigma A_i y_i &= 600 \times 15 \times \left(\frac{600}{2} + 20 \right) + 140 \times 10 \\ &\quad \times (70 + 30) \times 2 + 150 \times 10 \times (5 + 20) \\ &\quad \times 2 + 400 \times 20 \times 10 \\ &= 33,15,000 \text{ mm}^3\end{aligned}$$

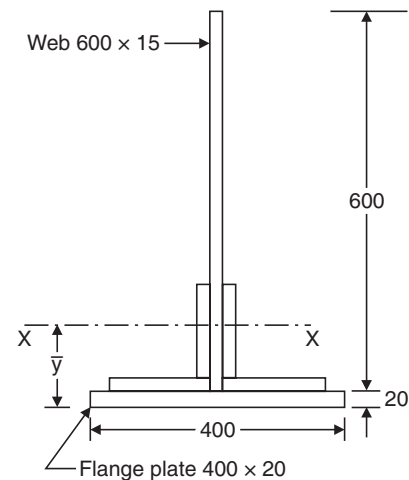

Fig. 4.61

$$A = 600 \times 15 + 140 \times 10 \times 2 + 150 \times 10 \times 2 + 400 \times 20$$

$$= 22,800 \text{ mm}^2$$

$$\therefore \bar{y} = \frac{\sum A_i y_i}{A} = \frac{3315000}{22800}$$

$$= 145.39 \text{ mm}$$

Moment of inertia of the section about centroidal axis } = { Sum of the moments of inertia of the all simple figures about centroidal axis

$$= \frac{15 \times 600^3}{12} + 600 \times 15(145.39 - 320)^2$$

$$+ \left[\frac{10 \times 140^3}{12} + 1400(145.39 - 100)^2 \right] \times 2$$

$$+ \left[\frac{150 \times 10^3}{12} + 1500 \times (145.39 - 15)^2 \right] \times 2$$

$$+ \frac{400 \times 20^3}{12} + 400 \times 20 \times (145.39 - 10)^2$$

$$I_{xx} = 7.45156 \times 10^8 \text{ mm}^4.$$

Example 4.21. Compute the moment of inertia of the 100 mm × 150 mm rectangle shown in Fig. 4.62 about x-x axis to which it is inclined at an angle

$$\theta = \sin^{-1} \left(\frac{4}{5} \right).$$

Solution: The rectangle is divided into four triangles as shown in the figure. [The lines AE and FC are parallel to x-axis].

$$\text{Now } \theta = \sin^{-1} \left(\frac{4}{5} \right) = 53.13^\circ$$

From the geometry of the Fig. 4.62,

$$BK = AB \sin (90^\circ - \theta)$$

$$= 100 \sin (90^\circ - 53.13^\circ)$$

$$= 60 \text{ mm}$$

$$ND = BK = 60 \text{ mm}$$

$$\therefore FD = \frac{60}{\sin \theta} = \frac{60}{\sin 53.13} = 75 \text{ mm}$$

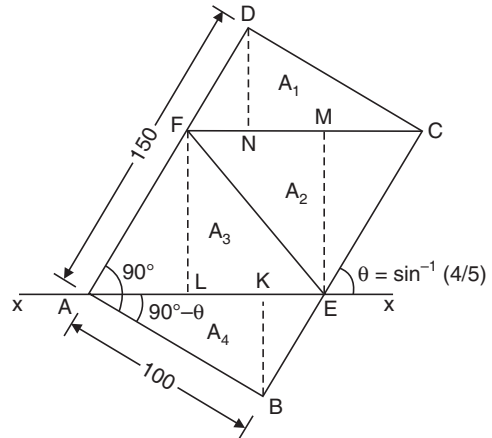

Fig. 4.62

$$\therefore AF = 150 - FD = 75 \text{ mm}$$

$$\text{Hence } FL = ME = 75 \sin \theta = 60 \text{ mm}$$

$$AE = FC = \frac{AB}{\cos(90^\circ - \theta)} = \frac{100}{0.8} = 125 \text{ mm}$$

Moment of inertia of the section about $x-x$ axis } = { Sum of the moments of inertia of individual triangular areas about $x-x$ axis

$$= I_{DFC} + I_{FCE} + I_{FEA} + I_{AEB}$$

$$= \frac{125 \times 60^3}{36} + \frac{1}{2} \times 125 \times 60 \times \left(60 + \frac{1}{3} \times 60\right)^2$$

$$+ \frac{125 \times 60^3}{36} + \frac{1}{2} \times 125 \times 60 \times \left(\frac{2}{3} \times 60\right)^2 + \frac{125 \times 60^3}{36} + \frac{1}{2} \times 125$$

$$\times 60 \times \left(\frac{1}{3} \times 60\right)^2 + \frac{125 \times 60^3}{36} + \frac{1}{2} \times 125 \times 60 \times \left(\frac{1}{3} \times 60\right)^2$$

$$I_{xx} = 3,60,00,000 \text{ mm}^4.$$

Example 4.22. Find moment of inertia of the shaded area shown in the Fig. 4.63 about the axis AB.

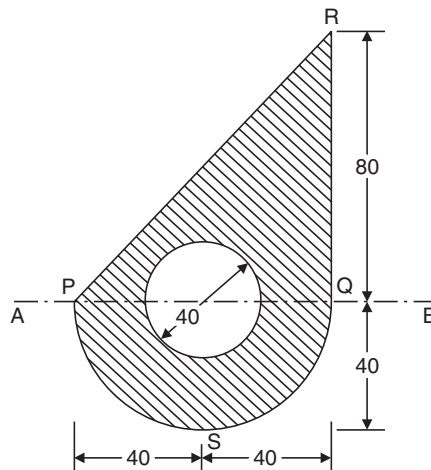

Fig. 4.63

Solution: The section is divided into a triangle PQR , a semicircle PSQ having base on axis AB and a circle having its centre on axis AB .

Now,

$$\left. \begin{array}{l} \text{Moment of inertia of the} \\ \text{section about axis } AB \end{array} \right\} = \begin{cases} \text{Moment of inertia of triangle } PQR \text{ about} \\ AB + \text{Moment of inertia of semicircle} \\ PSQ \text{ about } AB - \text{moment of inertia of} \\ \text{circle about } AB \end{cases}$$

$$= \frac{80 \times 80^3}{12} + \frac{\pi}{128} \times 80^4 - \frac{\pi}{64} \times 40^4$$

$$I_{AB} = 42,92,979 \text{ mm}^4.$$

Example 4.23. Find the second moment of the shaded portion shown in the Fig. 4.64 about its centroidal axis.

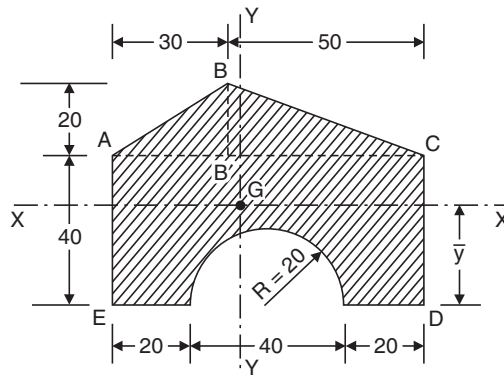

Fig. 4.64

Solution: The section is divided into three simple figures viz., a triangle ABC , a rectangle $ACDE$ and a semicircle.

Total Area = Area of triangle ABC + Area of rectangle $ACDE$ – Area of semicircle

$$A = \frac{1}{2} \times 80 \times 20 + 40 \times 80 - \frac{1}{2} \times \pi \times 20^2$$

$$= 3371.68$$

$$A \bar{y} = \frac{1}{2} \times 80 \times 20 \left(\frac{1}{3} \times 20 + 40 \right) + 40 \times 80 \times 20 - \frac{1}{2} \times \pi \times 20^2 \times \frac{4 \times 20}{3\pi}$$

$$= 95991.77$$

$$\therefore \bar{y} = \frac{95991.77}{3371.6} = 28.47 \text{ mm}$$

$$A \bar{x} = \frac{1}{2} \times 30 \times 20 \times \frac{2}{3} \times 30 + \frac{1}{2} \times 50 \times 20 \times \left(\frac{1}{3} \times 50 \times 30 \right)$$

$$+ 40 \times 80 \times 40 - \frac{1}{2} \times \pi \times 20^2 \times 40$$

$$= 132203.6$$

$$\therefore \bar{x} = \frac{A\bar{x}}{A} = \frac{132203.6}{3371.68} = 37.21 \text{ mm}$$

$$\left. \begin{array}{l} \text{Moment of inertia about} \\ \text{centroidal } x\text{-}x \text{ axis} \end{array} \right\} = \left\{ \begin{array}{l} \text{Moment of inertia of triangle } ABC \text{ about} \\ x\text{-}x \text{ axis} + \text{Moment of inertia of rectangle} \\ \text{about } x\text{-}x \text{ axis} - \text{moment of semicircle} \\ \text{about } x\text{-}x \text{ axis} \end{array} \right.$$

$$\begin{aligned} \therefore I_{xx} &= \frac{80 \times 20^3}{36} + \frac{1}{2} \times 80 \times 20 \left(60 - \frac{2}{3} \times 20 - 28.47 \right)^2 \\ &\quad + \frac{80 \times 40^3}{12} + 80 \times 40 \times (28.47 - 20)^2 \\ &\quad - \left[0.0068598 \times 20^4 + \frac{1}{2} \pi \times 20^2 \left(28.47 - \frac{4 \times 20}{3\pi} \right)^2 \right] \end{aligned}$$

$$I_{xx} = 6,86,944 \text{ mm}^4.$$

Similarly,

$$\begin{aligned} I_{yy} &= \frac{20 \times 30^3}{36} + \frac{1}{2} \times 20 \times 30 \left(39.21 - \frac{2}{3} \times 30 \right)^2 + \frac{20 \times 50^3}{36} \\ &\quad + \frac{1}{2} \times 20 \times 50 \times \left[39.21 - \left(30 + \frac{1}{3} \times 50 \right) \right]^2 + \frac{40 \times 80^3}{12} \\ &\quad + 40 \times 80(39.21 - 40)^2 - \frac{1}{2} \times \frac{\pi}{64} \times 40^4 - \frac{1}{2} \times \frac{\pi}{4} \\ &\quad \times 40^2 (40 - 39.21)^2 \\ &= 1868392 \text{ mm}^4. \end{aligned}$$

4.8 THEOREMS OF PAPPUS-GULDINUS

There are two important theorems, first proposed by Greek scientist (about 340 AD) and then restated by Swiss mathematician Paul Guldinus (1640) for determining the surface area and volumes generated by rotating a curve and a plane area about a non-intersecting axis, some of which are shown in Fig. 4.65. These theorems are known as Pappus-Guldinus theorems.

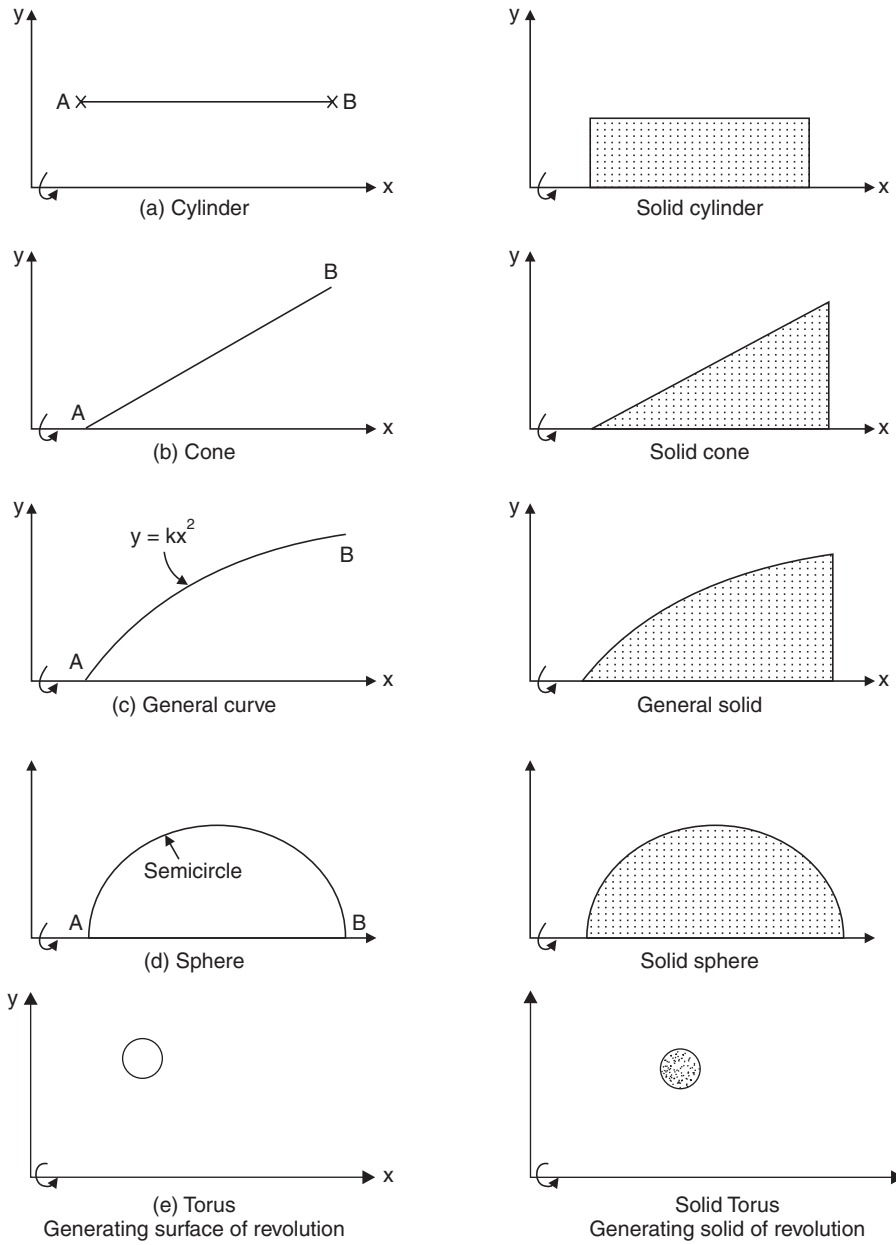

Fig. 4.65

Theorem I

The area of surface generated by revolving a plane curve about a non-intersecting axis in the plane of the curve is equal to the length of the generating curve times the distance travelled by the centroid of the curve in the rotation.

Proof: Figure 4.66 shows the isometric view of the plane curve rotated about x -axis by angle θ . We are interested in finding the surface area generated by rotating the curve AB . Let dL be the elemental length on the curve at D . Its coordinate be y . Then the elemental surface area generated by this element at D

$$\begin{aligned} dA &= dL(y \theta) \\ \therefore A &= \int dL(y \theta) \\ &= \theta \int y dL \\ &= \theta Ly_c \\ &= L (y_c \theta) \end{aligned}$$

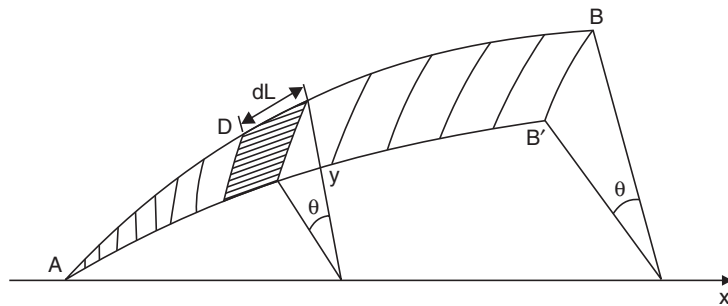

Fig. 4.66

Thus we get area of the surface generated as length of the generating curve times the distance travelled by the centroid.

Theorem II

The volume of the solid generated by revolving a plane area about a non-intersecting axis in the plane is equal to the area of the generating plane times the distance travelled by the centroid of the plane area during the rotation.

Proof: Consider the plane area ABC , which is rotated through an angle θ about x -axis as shown in Fig. 4.67.

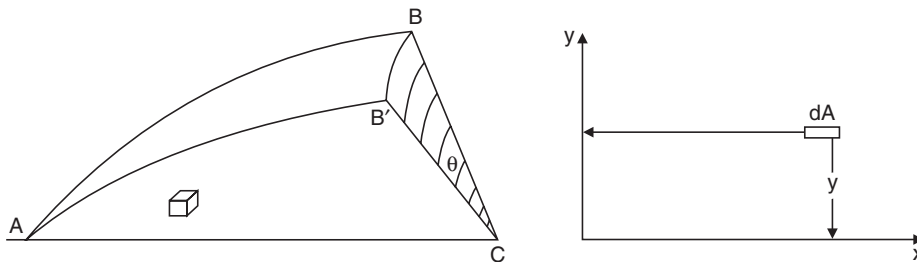

Fig. 4.67

Let dA be the elemental area of distance y from x -axis. Then the volume generated by this area during rotation is given by

$$\begin{aligned} dV &= dA/y\theta \\ \therefore V &= \int dA/y\theta \\ &= \theta \int y dA \\ &= \theta A y_c \\ &= A(y_c \theta) \end{aligned}$$

Thus the volume of the solid generated is area times the distance travelled by its centroid during the rotation. Using Pappus-Guldinus theorems surface area and volumes of cones and spheres can be calculated as shown below:

(i) *Surface area of a cone*: Referring to Fig. 4.68(a),
Length of the line generating cone = L

$$\text{Distance of centroid of the line from the axis of rotation} = y = \frac{R}{2}$$

In one revolution centroid moves by distance = $2\pi y = \pi R$

$$\therefore \text{Surface area} = L \times (\pi R) = \pi RL$$

(ii) *Volume of a cone*: Referring to Fig. 4.68(b),

$$\text{Area generating solid cone} = \frac{1}{2} hR$$

$$\text{Centroid } G \text{ is at a distance } y = \frac{R}{3}$$

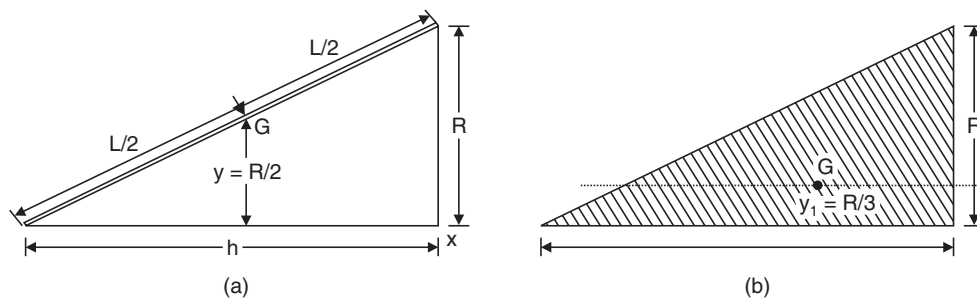

Fig. 4.68

$$\therefore \text{The distance moved by the centroid in one revolution} = 2\pi y = 2\pi \frac{R}{3}$$

$$\begin{aligned} \therefore \text{Volume of solid cone} &= \frac{1}{2} hR \times \frac{2\pi R}{3} \\ &= \frac{\pi R^2 h}{3} \end{aligned}$$

(iii) *Surface area of sphere*: Sphere of radius R is obtained by rotating a semi circular arc of radius R about its diametral axis. Referring to Fig. 4.69(a),

$$\text{Length of the arc} = \pi R$$

Centroid of the arc is at $y = \frac{2R}{\pi}$ from the diametral axis (i.e. axis of rotation)

\therefore Distance travelled by centroid of the arc in one revolution

$$= 2\pi y = 2\pi \frac{2R}{\pi} = 4R$$

\therefore Surface area of sphere $= \pi R \times 4R$

$$= 4\pi R^2$$

(iv) *Volume of sphere*: Solid sphere of radius R is obtained by rotating a semicircular area about its diametral axis. Referring to Fig. 4.69(b).

$$\text{Area of semicircle} = \frac{\pi R^2}{2}$$

Distance of centroid of semicircular area from its centroidal axis

$$= y = \frac{4R}{3\pi}$$

\therefore The distance travelled by the centroid in one revolution

$$= 2\pi y = 2\pi \frac{4R}{3\pi} = \frac{8R}{3}$$

\therefore Volume of sphere $= \frac{\pi R^2}{2} \times \frac{8R}{3}$

$$= \frac{4\pi R^3}{3}$$

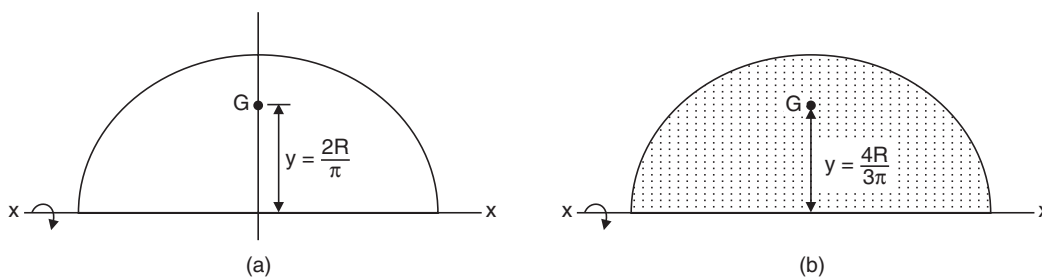

Fig. 4.69

4.9 CENTRE OF GRAVITY OF SOLIDS

Centre of gravity of solids may be found using eqn. (4.1) which will be same as those found from eqns. (4.2) and (4.3) if the mass is uniform. Hence centre of gravity of solids, centre of gravity of mass or centroid of volumes is the same for all solids with uniform mass. For standard solids, the

centre of gravity may be found from first principle and the results obtained for standard solids may be used to find centre of gravity of composite solids. The procedure is illustrated with examples 4.24 to 4.27.

Example 4.24. Locate the centre of gravity of the right circular cone of base radius r and height h shown in Fig. 4.70.

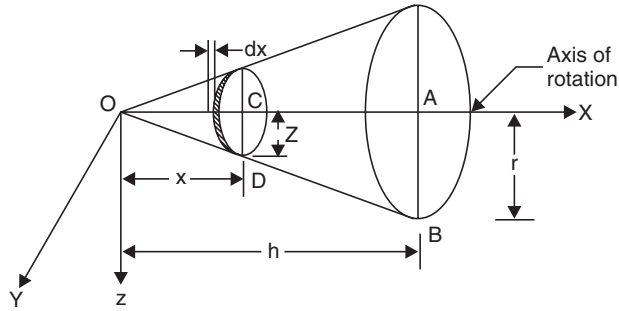

Fig. 4.70

Solution: Taking origin at the vertex of the cone and selecting the axis as shown in Fig. 4.70, it can be observed that due to symmetry the coordinates of centre of gravity \bar{y} and \bar{z} are equal to zero, i.e. the centre of gravity lies on the axis of rotation of the cone. To find its distance \bar{x} from the vertex, consider an elemental plate at a distance x . Let the thickness of the elemental plate be dx . From the similar triangles OAB and OCD , the radius of elemental plate z is given by

$$z = \frac{x}{h} r$$

∴ Volume of the elemental plate dv

$$dv = \pi z^2 dx = \pi x^2 \frac{r^2}{h^2} dx$$

If γ is the unit weight of the material of the cone, then weight of the elemental plate is given by:

$$dW = \gamma \pi x^2 \frac{r^2}{h^2} dx \quad \dots(i)$$

$$W = \int_0^h \gamma \frac{\pi r^2}{h^2} x^2 dx$$

$$= \gamma \frac{\pi r^2}{h^2} \left[\frac{x^3}{3} \right]_0^h$$

$$= \gamma \pi \frac{r^2 h}{3} \quad \dots(ii)$$

[**Note:** $\frac{\pi r^2 h}{3}$ is volume of cone]

Now, substituting the value of dW in (i), above, we get:

$$\int x \cdot dW = \int_0^h \gamma \frac{\pi r^2}{h^2} x^2 \cdot x \cdot dx$$

$$\begin{aligned}
 &= \gamma \frac{\pi r^2}{h^2} \left[\frac{x^4}{4} \right]_0^h \\
 &= \gamma \frac{\pi r^2 h^2}{4} \qquad \dots(iii)
 \end{aligned}$$

From eqn. 4.1,

$$W\bar{x} = \int x dW$$

i.e.,
$$\frac{\pi r^2 h}{3} \bar{x} = \frac{\gamma \pi r^2 h^2}{4}$$

$$\therefore \bar{x} = \frac{3}{4} h$$

Thus, in a right circular cone, centre of gravity lies at a distance $\frac{3}{4} h$ from vertex along the axis of rotation i.e., at a distance $\frac{h}{4}$ from the base.

Example 4.25. Determine the centre of gravity of a solid hemisphere of radius r from its diametral axis.

Solution: Due to symmetry, centre of gravity lies on the axis of rotation. To find its distance \bar{x} from the base along the axis of rotation, consider an elemental plate at a distance x as shown in Fig. 4.71.

Now,
$$x^2 + z^2 = r^2$$

$$z^2 = r^2 - x^2$$

Volume of elemental plate

$$dv = \pi z^2 dx = \pi(r^2 - x^2)dx$$

\therefore Weight of elemental plate

$$dW = \gamma dv = \gamma \pi(r^2 - x^2)dx$$

\therefore Weight of hemisphere

$$W = \int dW = \int_0^r \gamma \pi(r^2 - x^2)dx$$

$$= \gamma \pi \left[r^2 x - \frac{x^3}{3} \right]_0^r$$

$$= \frac{2\gamma \pi r^3}{3}$$

Moment of weight about z axis

$$= \int_0^r x dW$$

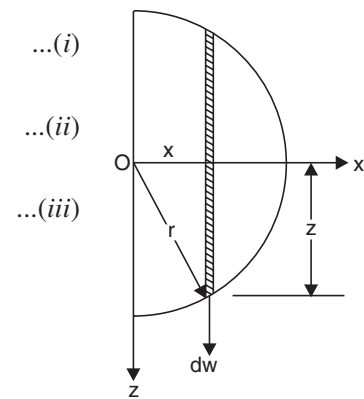

Fig. 4.71

$\dots(iv)$

$$\begin{aligned}
 &= \int_0^r x \pi(r^2 - x^2) dx \\
 &= \pi \left[r^2 \frac{x^2}{2} - \frac{x^4}{4} \right]_0^r \\
 &= \frac{\pi r^4}{4} \qquad \dots(v)
 \end{aligned}$$

∴ \bar{x} , the distance of centre of gravity from base is given by:

$$W\bar{x} = \int_0^r x dw$$

i.e., From (iv) and (v) above, we get

$$\frac{2\gamma\pi r^3}{3} \bar{x} = \frac{\gamma\pi r^4}{4} \qquad \bar{x} = \frac{3}{8} r$$

Thus, the centre of gravity of a solid hemisphere of radius r is at a distance $\frac{3}{8} r$ from its diametral axis.

Example 4.26. Determine the maximum height h of the cylindrical portion of the body with hemispherical base shown in Fig. 4.72 so that it is in stable equilibrium on its base.

Solution: The body will be stable on its base as long as its centre of gravity is in hemispherical base. The limiting case is when it is on the plane $x-x$ shown in the figure.

Centroid lies on the axis of rotation.

Mass of cylindrical portion

$$m_1 = \pi r^2 h \rho, \text{ where } \rho \text{ is unit mass of material.}$$

Its centre of gravity g_1 is at a height

$$z_1 = \frac{h}{2} \text{ from } x \text{ axis.}$$

Mass of hemispherical portion

$$m_2 = \rho \frac{2\pi r^3}{3}$$

and its CG is at a distance

$$z_2 = \frac{3r}{8} \text{ from } x-x \text{ plane.}$$

Since centroid is to be on $x-x$ plane $\bar{z} = 0$

i.e., $\Sigma m_i z_i = 0$

$$\therefore \frac{m_1 h}{2} - m_2 \frac{3}{8} r = 0$$

$$\pi r^2 h \rho \frac{h}{2} = \rho \frac{2\pi r^3}{3} \frac{3}{8} r$$

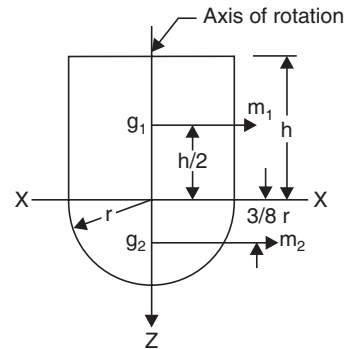

Fig. 4.72

$$\therefore h^2 = \frac{1}{2} r^2$$

$$\text{or } h = \frac{r}{\sqrt{2}} = 0.707 r$$

Example 4.27. A concrete block of size $0.60 \text{ m} \times 0.75 \text{ m} \times 0.5 \text{ m}$ is cast with a hole of diameter 0.2 m and depth 0.3 m as shown in Fig. 4.73. The hole is completely filled with steel balls weighing 2500 N . Locate the centre of gravity of the body. Take the weight of concrete = 25000 N/m^3 .

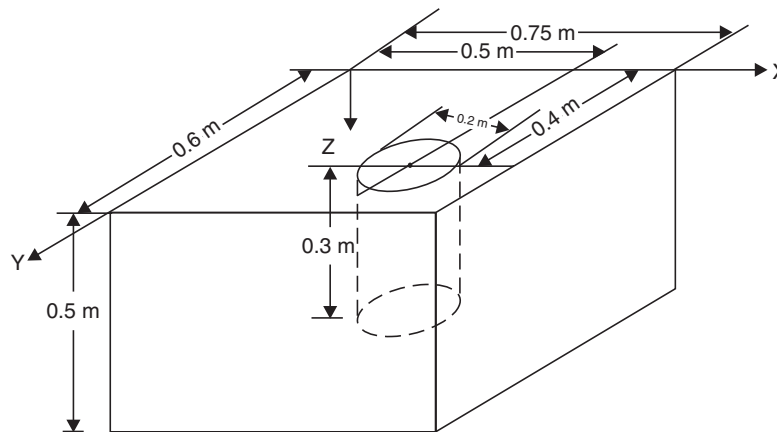

Fig. 4.73

Solution: Weight of solid concrete block:

$$W_1 = 0.6 \times 0.75 \times 0.5 \times 25000 = 5625 \text{ N}$$

Weight of concrete (W_2) removed for making hole:

$$W_2 = \frac{\pi}{4} \times 0.2^2 \times 0.3 \times 25000 = 235.62 \text{ N}$$

Taking origin as shown in the figure, the centre of gravity of solid block is $(0.375, 0.3, 0.25)$ and that of hollow portion is $(0.5, 0.4, 0.15)$. The following table may be prepared now:

Table

Simple Body	W_i	x_i	$W_i x_i$	y_i	$W_i y_i$	z_i	$W_i z_i$
1. Solid block	5625	0.375	2109.38	0.3	1687.5	0.25	1406.25
2. Hole in concrete block	-235.62	0.5	-117.81	0.4	-94.25	0.15	-35.34
3. Steel balls	2500	0.5	1250.0	0.4	1000.0	0.15	375.0

$$\Sigma W_i = 7889.38 \quad \Sigma W_i x_i = 3241.57 \quad \Sigma W_i y_i = 2593.25 \quad \Sigma W_i z_i = 1745.91$$

$$\therefore \bar{x} = \frac{\Sigma W_i x_i}{W} = \frac{\Sigma W_i x_i}{\Sigma W_i} \quad \bar{x} = \frac{3241.57}{7889.38} = 0.411 \text{ m}$$

$$\text{Similarly, } \bar{y} = \frac{2593.25}{7887.38} = 0.329 \text{ m}$$

$$\bar{z} = \frac{1745.91}{7889.38} = 0.221 \text{ m}$$

IMPORTANT FORMULAE

1. Area of sector of a circle = $R^2 \alpha$
2. Area of parabolic spandrel
 - (i) if $y = kx^2$, $A = \frac{1}{3}ha = \frac{1}{3} \times$ the area of rectangle of size $a \times h$
 - (ii) if $y^2 = kx$, $A = \frac{2}{3}ha = \frac{2}{3} \times$ the area of rectangle of size $a \times h$.
3. Surface area of the cone = πRl
4. Surface area of the sphere = $4\pi R^2$
5. Volume of a cone = $\frac{\pi R^2 h}{3}$
6. Volume of a sphere = $\frac{4}{3} \pi R^3$
7. Centroid of a arc of a circle is at $x_c = \frac{R \sin \alpha}{\alpha}$ from the centre of circle on the symmetric axis.
8. Centroid of a composite figure is given by

$$x_c = \frac{\sum A_i x_i}{A}, \quad y_c = \frac{\sum A_i y_i}{A}.$$
9. Centroid of simple figure from the reference axis

$$\bar{y} = \frac{\int y dA}{A}.$$
10. For centroid of standard figures refer Table 4.2.
11. $I_{yy} = \sum x_i^2 dA_i$ and $I_{xx} = \sum y_i^2 dA_i$, $I_{zz} = \sum r_i^2 dA_i = \int r^2 dA$.
12. Radius of gyration $k = \sqrt{\frac{I}{A}}$ i.e. $I = Ak^2$.
13. $I_{zz} = I_{xx} + I_{yy}$.
14. $I_{AB} = I_{GG} + Ay_c^2$.
15. Moment of inertia of standard sections are as shown in Table 4.4.
16. Pappus-Guldinus Theorems:
 - (i) The area of surface generated by revolving a plane curve about a non-intersecting axis in the plane of the curve is equal to the length of the generating curve times the distance travelled by the centroid of the curve in the rotation.
 - (ii) The volume of the solid generated by a plane area about a non-intersecting axis in the plane is equal to the area of the generating plane times the distance travelled by the centroid of the plane area during the rotation.

17. In a right circular cone, the centre of gravity lies at a distance $\frac{3}{4} \times$ height from the vertex along the axis of rotation.
18. The centre of gravity of a solid hemisphere of radius r is at a distance $\frac{3}{8} \times r$ from its diametral axis.

THEORY QUESTIONS

- Determine the centroid of an arc of radius R from first principle.
- Distinguish between centroid and centre of gravity.
- Determine the centroid of a triangle of base width ' b ' and height ' h ' by the method of integration.
- Locate the centroid of a semicircle from its diametral axis using the method of integration.
- Explain the terms moment of inertia and radius of gyration of a plane figure.
- State and prove
 - Perpendicular axis theorem
 - Parallel axis theorem of moment of inertia.
- Determine the moment of inertia of the areas specified below by first principle:
 - Triangle of base width b and height h about its centroid axis parallel to the base.
 - A semicircle about its centroidal axis parallel to the diametral axis.
- State and explain theorems of Pappus-Guldinus.
- Locate the centre of gravity of the right circular cone of base radius R and height h .
- Determine the centre of gravity of a solid hemisphere of radius R from its diametral axis.

PROBLEMS FOR EXERCISE

- Determine the centroid of the built-up section in Fig. 4.74. Express the coordinates of centroid with respect to x and y axes shown. [Ans. $\bar{x} = 48.91$ mm; $\bar{y} = 61.30$ mm]

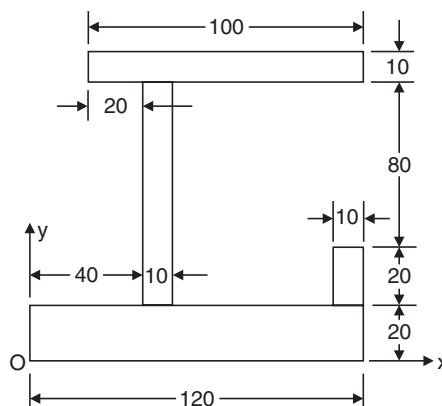

Fig. 4.74

2. Determine the centroid of the reinforced concrete retaining wall section shown in Fig. 4.75.
 [Ans. $\bar{x} = 1.848$ m; $\bar{y} = 1.825$ m]

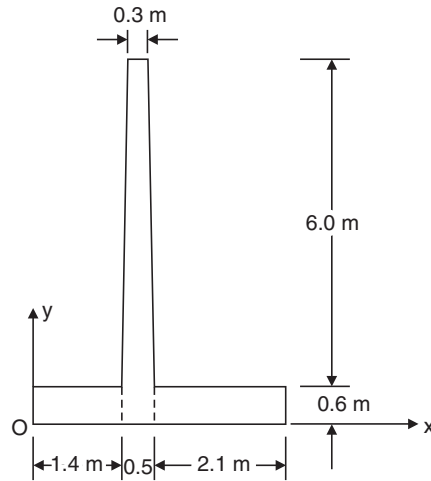

Fig. 4.75

3. Find the coordinates of the centroid of the shaded area with respect to the axes shown in Fig. 4.76.
 [Ans. $x = 43.98$ mm; $y = 70.15$ mm]

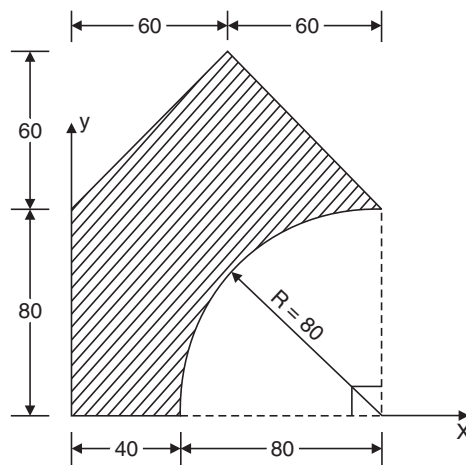

Fig. 4.76

4. A circular plate of uniform thickness and of diameter 500 mm as shown in Fig. 4.77 has two circular holes of 40 mm diameter each. Where should a 80 mm diameter hole be drilled so that the centre of gravity of the plate will be at the geometric centre.
 [Ans. $x = 50$ mm; $y = 37.5$ mm]

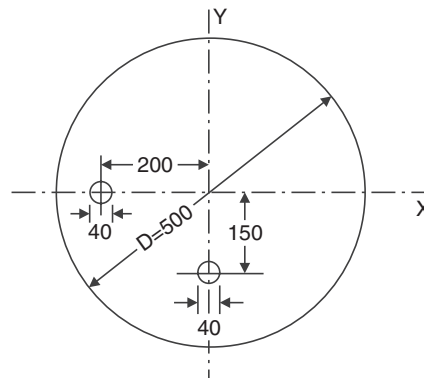

Fig. 4.77

5. With respect to the coordinate axes x and y locate the centroid of the shaded area shown in Fig. 4.78. [Ans. $\bar{x} = 97.47$ mm; $\bar{y} = 70.77$ mm]

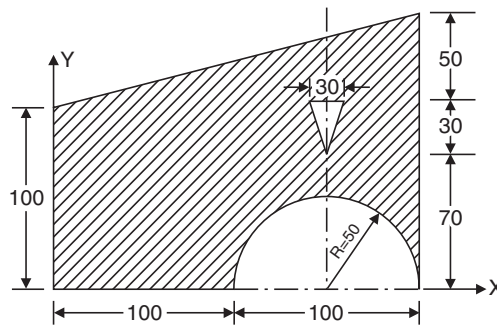

Fig. 4.78

6. Locate the centroid of the plane area shown in Fig. 4.79.

[Ans. $\bar{x} = 104.10$ mm; $\bar{y} = 44.30$ mm]

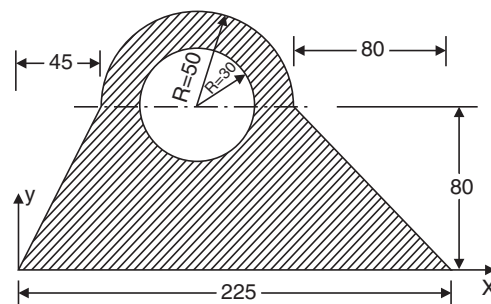

Fig. 4.79

7. Determine the coordinates of the centroid of shaded as shown in Fig. 4.80 with respect to the corner point O . Take $x = 40$ mm. [Ans. $\bar{x} = 260.07$ mm; $\bar{y} = 113.95$ mm]

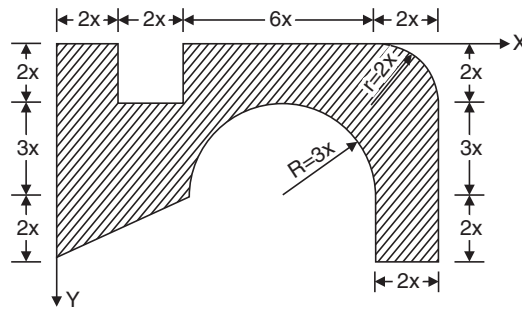

Fig. 4.80

8. $ABCD$ is a square section of sides 100 mm. Determine the ratio of moment of inertia of the section about centroidal axis parallel to a side to that about diagonal AC . [Ans. 1]
9. The cross-section of a rectangular hollow beam is as shown in Fig. 4.81. Determine the polar moment of inertia of the section about centroidal axes.

[Ans. $I_{xx} = 1,05,38,667 \text{ mm}^4$; $I_{yy} = 49,06,667 \text{ mm}^4$; $I_{zz} = 1,54,45,334 \text{ mm}^4$]

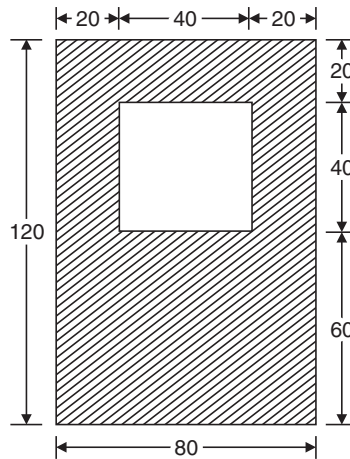

Fig. 4.81

10. The cross-section of a prestressed concrete beam is shown in Fig. 4.82. Calculate the moment of inertia of this section about the centroidal axes parallel to and perpendicular to top edge. Also determine the radii of gyration. [Ans. $I_{xx} = 1.15668 \times 10^{10} \text{ mm}^4$; $k_{xx} = 231.95 \text{ mm}$; $I_{yy} = 8.75729 \times 10^9 \text{ mm}^4$; $k_{yy} = 201.82 \text{ mm}$]

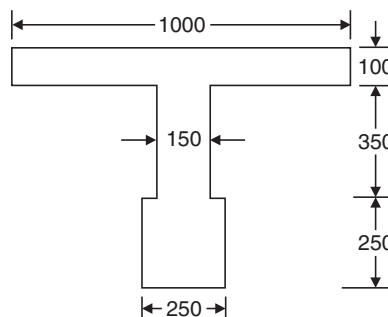

Fig. 4.82

11. The strength of a 400 mm deep and 200 mm wide *I*-beam of uniform thickness 10 mm, is increased by welding a 250 mm wide and 20 mm thick plate to its upper flanges as shown in Fig. 4.83. Determine the moment of inertia and the radii of gyration of the composite section with respect to centroidal axes parallel to and perpendicular to the bottom edge *AB*.

[Ans. $I_{xx} = 3.32393 \times 10^8 \text{ mm}^4$; $k_{xx} = 161.15 \text{ mm}$;
 $I_{yy} = 3,94,06,667 \text{ mm}^4$; $k_{yy} = 55.49 \text{ mm}$]

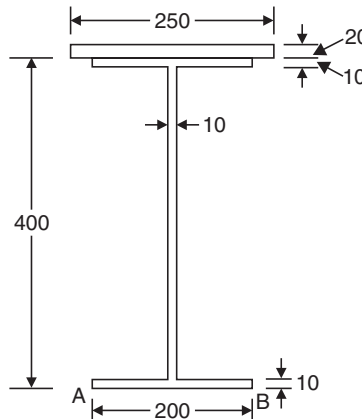

Fig. 4.83

12. The cross-section of a gantry girder is as shown in Fig. 4.84. It is made up of an *I*-section of depth 450 mm, flange width 200 mm and a channel of size 400 mm \times 150 mm. Thickness of all members is 10 mm. Find the moment of inertia of the section about the horizontal centroidal axis.

[Ans. $I_{xx} = 4.2198 \times 10^8 \text{ mm}^4$]

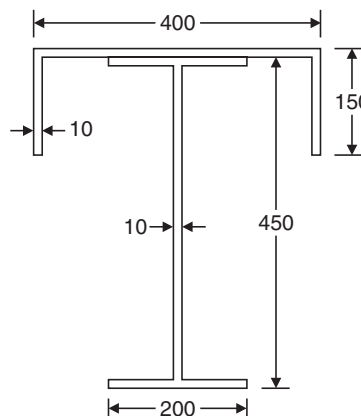

Fig. 4.84

13. A plate girder is made up of a web plate of size 400 mm \times 10 mm, four angles of size 100 mm \times 100 mm \times 10 mm and cover plates of size 300 mm \times 10 mm as shown in Fig. 4.85. Determine the moment of inertia about horizontal and vertical centroidal axes.

[Ans. $I_{xx} = 5.35786 \times 10^8 \text{ mm}^4$; $I_{yy} = 6,08,50,667 \text{ mm}^4$]

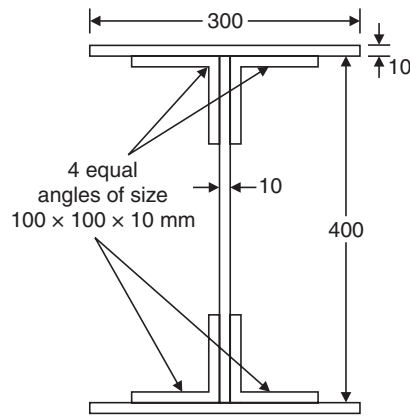

Fig. 4.85

14. Determine the moment of inertia and radii of gyration of the area shown in Fig. 4.86 about the base $A-B$ and the centroidal axis parallel to AB .

[Ans. $I_{AB} = 48,15,000 \text{ mm}^4$; $I_{xx} = 18,24,231 \text{ mm}^4$
 $k_{AB} = 35.14 \text{ mm}$; $k_{xx} = 21.62 \text{ mm}$]

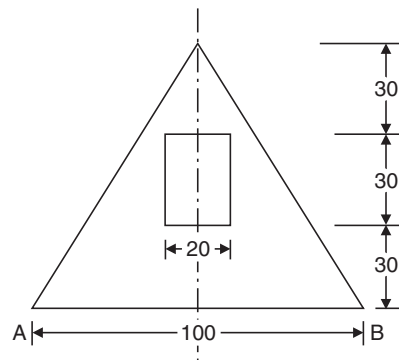

Fig. 4.86

15. Determine the moment of inertia of the section shown in Fig. 4.87 about the vertical centroidal axis.

[Ans. $I_{yy} = 5,03,82,857 \text{ mm}^4$]

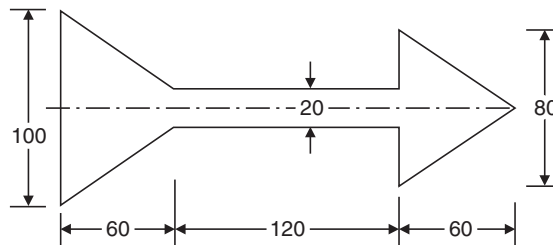

Fig. 4.87

16. A semi-circular cut is made in rectangular wooden beam as shown in Fig. 4.88. Determine the polar moment of inertia of the section about the centroidal axis.

[Ans. $I_{xx} = 3,35,81,456 \text{ mm}^4$; $I_{yy} = 1,00,45,631 \text{ mm}^4$; $I_{zz} = 2,20,98,980 \text{ mm}^4$]

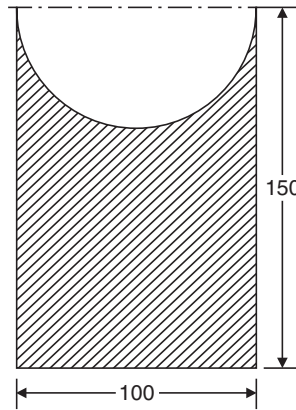

Fig. 4.88

17. Determine the moment of inertia of the section shown in the Fig. 4.89 about the horizontal centroidal axis. Also find the moment of inertia of the section about the symmetrical axis. Hence find the polar moment of inertia.

[Ans. $I_{xx} = 54,09,046 \text{ mm}^4$; $I_{yy} = 14,55,310 \text{ mm}^4$; $I_{zz} = 68,64,356 \text{ mm}^4$]

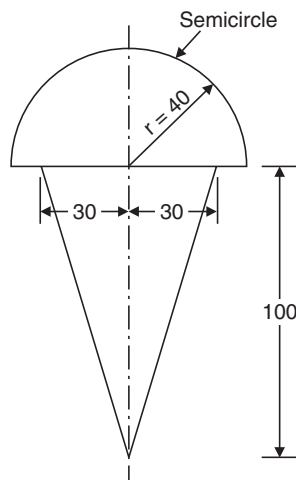

Fig. 4.89

18. The cross-section of a machine part is as shown in Fig. 4.90. Determine its moment of inertia and radius of gyration about the horizontal centroidal axis.

[Ans. $I_{xx} = 5249090.85 \text{ mm}^4$; $k_{xx} = 27.05 \text{ mm}$]

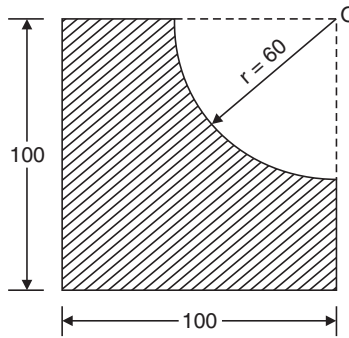

Fig. 4.90

19. The cross-section of a plain concrete culvert is as shown in Fig. 4.91. Determine the moment of inertia about the horizontal centroidal axes. [Ans. $I_{xx} = 5.45865 \times 10^{10} \text{ mm}^4$]

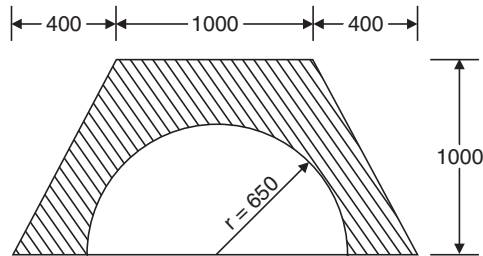

Fig. 4.91

20. Determine the centroid of the built-up section shown in Fig. 4.92 and find the moment of inertia and radius of gyration about the horizontal centroidal axis.

[Ans. $I_{xx} = 1267942 \text{ mm}^4$; $k_{xx} = 18.55 \text{ mm}$]

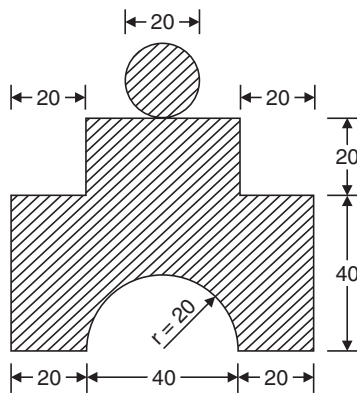

Fig. 4.92

21. Determine the centre of gravity of the pyramid shown in Fig. 4.93.

[Ans. $x = \frac{3}{4} h$]

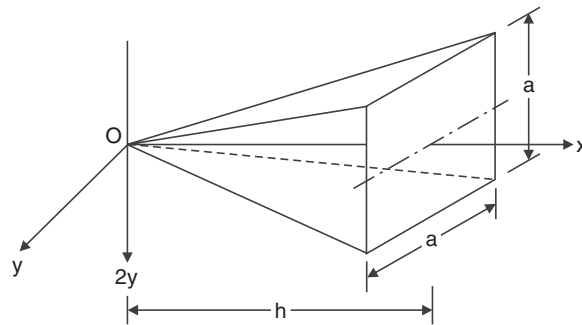

Fig. 4.93

22. A steel ball of diameter 150 mm rests centrally over a concrete cube of size 150 mm. Determine the centre of gravity of the system, taking weight of concrete = 25000 N/m^3 and that of steel 80000 N/m^3 .
 [Ans. 168.94 mm from base]
23. Locate the centre of gravity of the wire shown in Fig. 4.94. Portion BC is in x - y plane and semicircle CD is parallel to x - z plane.

[Ans. $\bar{x} = 124.02 \text{ mm}$; $\bar{y} = 110.41 \text{ mm}$; $\bar{z} = 11.28 \text{ mm}$]

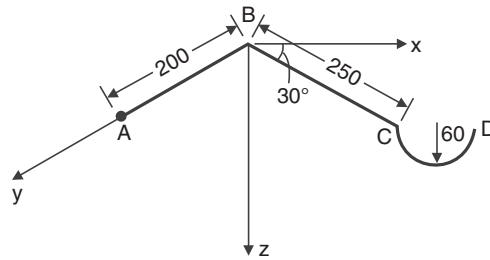

Fig. 4.94